

OPERATOR'S MANUAL  
AND  
SAFETY INSTRUCTIONS  
WITH INSTALLATION, TROUBLESHOOTING,  
INSPECTION AND MAINTENANCE INSTRUCTIONS

**SMART-C** SERIES  
Microprocessor Controlled  
Chuck Control



**O.S. WALKER**

Rockdale Street, Worcester, MA 01606 (508)-853-3232 FAX (508)-852-8649  
3508 Glenridge Drive, Chino Hills, CA 91709 (909)-597-4785 FAX (909)-597-0581  
901 Arvin Avenue, Stoney Creek, Ontario, L8E5N9 Canada (905)-643-3338  
In Canada: 1-800-267-4678 FAX (905)-643-6111

[www.walkermagnet.com](http://www.walkermagnet.com)  
Email: [info@walkermagnet.com](mailto:info@walkermagnet.com)

**! DANGER**

**Never attempt to operate this control until you have read and understand this OPERATOR'S MANUAL.**



# TABLE OF CONTENTS

<b>1 INTRODUCTION</b>	<b>1-1</b>
<b>2 SAFETY INSTRUCTIONS</b>	<b>2-1</b>
2.1 GENERAL SAFETY RULES	2-1
2.2 RECOGNIZE SAFETY INFORMATION	2-2
2.2.1 <i>Ways to Avoid a Reduction of Holding Capacity</i>	2-2
2.3 ADDITIONAL WARNINGS	2-3
2.4 DESIGNATED PERSON	2-3
<b>3 INSTALLATION</b>	<b>3-1</b>
3.1 CONTROL MOUNTING GUIDELINES	3-1
3.1.1 <i>Connecting Additional Features</i>	3-1
3.1.1.1 Current Sensing	3-1
3.1.1.2 Lockout	3-1
<b>4 OPERATING INSTRUCTIONS</b>	<b>4-1</b>
4.1 IMPORTANT FACTS ABOUT MAGNETIC HOLDING	4-1
4.1.1 <i>Surface Conditions</i>	4-2
4.1.2 <i>Workpiece Thickness</i>	4-2
4.1.3 <i>Portion of the Chuck Surface In Contact With the Workpiece</i>	4-2
4.1.4 <i>Workpiece Material</i>	4-3
4.2 RELEASE	4-3
4.3 FULL HOLDING	4-4
4.4 VARIABLE HOLDING	4-4
4.5 RESIDUAL HOLDING	4-5
4.6 CURRENT SENSE	4-5
4.7 CONTROL PROTECTION	4-5
4.8 RELEASE CYCLE STEPS	4-5
4.9 GROUNDING & SHIELDING	4-7
4.10 CONTROL OUTPUT VOLTAGE	4-7
<b>5 INSPECTION &amp; MAINTENANCE</b>	<b>5-1</b>
5.1 DAILY INSPECTION	5-1
5.2 HAVING A PROBLEM WITH YOUR CHUCK CONTROL?	5-1
5.2.1 <i>Main Pc Board</i>	5-3
5.3 CHUCK CONTROL CONNECTIONS	5-7
5.3.1 <i>Model SMART-C</i>	5-7
5.3.2 <i>Adjustments</i>	5-7
<b>6 REPLACEMENT PARTS LIST</b>	<b>6-1</b>
6.1 SMART-C CONTROLS	6-1
<b>7 RETURN AND REPAIR INSTRUCTIONS</b>	<b>7-1</b>

## TABLE OF TABLES

TABLE 5-1 CONNECTOR J8 (MAIN P.C. BOARD).....	5-7
TABLE 5-2 CONNECTOR J1 (MAIN P.C. BOARD).....	5-7
TABLE 5-3 CONNECTOR J4 (MAIN P.C. BOARD).....	5-7
TABLE 6-1 REPLACEMENT PARTS LIST .....	6-1

## TABLE OF FIGURES

FIGURE 4-1 RELEASE CYCLE VOLTAGE VS. RELEASE CYCLE TIME.....	4-6
FIGURE 5-1 MAIN PC BOARD .....	5-3
FIGURE 5-2 TRANSFORMER WIRING FOR SMART-3C & 5C .....	5-4
FIGURE 5-3 ENCLOSURE DIMENSIONS FOR SMART-C CONTROL .....	5-5
FIGURE 5-4 ENCLOSURE ASSEMBLY .....	5-6

# 1 INTRODUCTION

Thank you for purchasing this O.S. Walker Chuck Control. If used and maintained properly, it should serve you for many years. However, if installed and used improperly, it can be rendered inefficient and unsafe. Therefore, it is absolutely essential that anyone who uses this control or is responsible for its application be trained on how to use it correctly.

**Read this manual carefully to learn how to operate and maintain your chuck control. Failure to do so could result in serious injury, or even death, to yourself and others.**

**This manual should be considered a permanent part of your control and should always be available to all operators and remain with the control if it is re-sold.**

**NOTE: Before using this chuck control, record this data from the nameplate for future use in obtaining service.**

**MODEL NO. \_\_\_\_\_, PART NO. \_\_\_\_\_, SERIAL NO. \_\_\_\_\_**

To request additional copies of this manual, call 1-800-962-4638 in the USA;  
In Canada: 905-643-3338; In Europe: 31-4973-83835

## 2 SAFETY INSTRUCTIONS

### 2.1 General Safety Rules

Following these simple rules can help to avoid accidents:

# DANGER

- **Never** attempt to operate this control and your magnetic chuck until you read and understand this operator's manual.
- **Never** disconnect a magnetic chuck from the control's DC power source while it is energized! Electrical arcing will occur and may cause serious injury or death.
- **Only** qualified personnel shall make adjustments within the control while it is energized!
- **Never** operate the control and chuck until it has been verified that a proper electrical ground for the control and Chuck has been established.
- **Never** operate damaged or malfunctioning controls or magnetic chucks.

Remember, proper knowledge and techniques in the use of this equipment are the responsibility of the operator. Be sure to read and understand the instructions and safety warnings contained in this manual before using your chuck control and magnetic chuck.

If you do not understand everything in this manual contact O.S. Walker for assistance before using the equipment.

**CALL 1-800-W-MAGNET** IN THE USA  
(In Canada call 905-643-3338; In Europe 31-4973-83835)

## 2.2 Recognize Safety Information



This is the safety alert symbol. When you see this symbol on your magnet or in this manual, be alert to the potential for personal injury. Follow recommended precautions and safe operating practices at all times.

**! DANGER**

Red Background, White Letters

**! WARNING**

Orange Background, Black Letters

**! CAUTION**

Yellow Background, Black Letters

This indicates a situation in which a hazard is imminent and will result in a high probability of serious injury or death.

This indicates a potentially hazardous situation, which could result in some probability of serious injury or death.

This indicates a potentially hazardous situation, which could result in minor injury or moderate injury.

**These are  
Hazard  
Seriousness  
Signal  
Words**

### 2.2.1 Ways to Avoid a Reduction of Holding Capacity

**! WARNING**

#### To Avoid any Reduction of Holding Capacity:

- The holding surface of the chuck and the contact area of the workpiece where it will contact the chuck must be clean, smooth, flat, and free of nicks and burrs.
  - The surface of the workpiece must contact equal areas of the chuck's opposite polarity, major magnetic poles.
  - The load must be low carbon steel such as SAE 1020.
  - The chuck control must provide "FULL" power to the chuck, that is, maximum output voltage.
  - The workpiece thickness must be at least equal or greater than the width of the chuck's major magnetic poles.
  - The temperature inside the chuck control enclosure must not be greater than 104° Fahrenheit (40° Celsius), nor the temperature of the chuck must not be greater than 110° F (43° C).
  - Repair of this chuck control should only be done by the O. S. Walker Co.\*
- If you have any difficulty holding a work piece, DON'T attempt to machine it! Call the O.S. Walker Co. for advice at 1-800-962-4638.

## 2.3 Additional Warnings

### **WARNING**

- Disassembly or repair of this chuck control can result in reduced holding power and/or cause an unsafe condition. Therefore, any time the control is disassembled or repaired it should be thoroughly inspected and re-tested for proper electrical grounding and power output.
- Modification of any operating circuits and electrical safety grounding can reduce the chuck control's effectiveness and/or cause an unsafe condition.
- Repair of this chuck control should only be done by the O. S. Walker Co.\*

## 2.4 Designated Person

\* Walker replacement parts may be installed by a **\*\*Designated Person**.

**\*\* Designated Person** - A person selected or assigned by the employer as being competent to replace specific parts listed in this manual and is able to verify the proper functioning of the specific replacement parts and the entire product after the completion of the installation.

### **WARNING**

#### **ELECTRICAL GROUNDING**

Because the O. S. Walker Co. does not know the specifics of each application and installation of these products and the electromagnetic device to which they are attached, it can only warn the installer and user that the electrically conductive body of the electromagnetic device **MUST** be connected to a proper electrical ground.

According to ANSI/NFPA 79 1997(an American National Standard) "Electrical Standard for Industrial Machinery":

- Section 19.3 Equipment Grounding: The machine and all exposed noncurrent-carrying conductive parts, material, and equipment, including metal mounting panels that are likely to become energized and are mounted in nonmetallic enclosures, shall be effectively grounded.
- Section 19.2.4 Grounding Conductors: It shall be permissible to use machine members or structural parts of the electrical equipment in the grounding circuit provided that the cross-sectional area of these parts is at least electrically equivalent to the minimum cross-sectional area of the copper conductor required.
- Section 19.6.1 Continuity of the Grounding Circuit: The continuity of the grounding circuit shall be ensured by effective connections through conductors or structural members.
- Section 19.6.3 Continuity of the Grounding Circuit: Moving machine parts, other than accessories or attachments, having metal-to-metal bearing surfaces shall be considered as bonded. Sliding parts separated by a non-conductive fluid under pressure shall not be considered as bonded.

**PRIOR TO ENERGIZING THE ELECTROMAGNETIC DEVICE, CHECK ALL THE ELECTRICAL CONNECTIONS AND CONFIRM THAT THE METAL BODY OF THE ELECTROMAGNETIC DEVICE IS ELECTRICALLY GROUNDED.**



## 3 INSTALLATION

# WARNING

- All electrical chassis must be safety grounded.
- Check that all sources of power are disconnected, locked out and tagged “Out of Service” prior to beginning installation.
- Only qualified personnel should install this chuck control unit.

Prior to beginning, thoroughly plan your installation. Read this manual completely. An installation parts list is included below to aid in your planning.

### **3.1 Control Mounting Guidelines**

1. When any control (power section) is removed from its original enclosure or shipped without an enclosure and installed in a customer supplied enclosure, the following specifications must be met:
  - a. The air surrounding the panel on which the parts are located should not exceed 120° Fahrenheit.
  - b. The air temperature must be measured:
    - 1) With the control in the Full holding position;
    - 2) After the control has been in operation for 30 minutes; and
    - 3) With the chuck holding the largest load to be used.
2. When any control (power section) is to be placed in a secondary enclosure while still in its original enclosure, the following specifications must be met:
  - a. With the control (power section) mounted in its original enclosure and then mounted in a secondary enclosure, the air surrounding the original enclosure should not exceed 104° Fahrenheit.
  - b. The air temperature must be measured:
    - 1) With the control in the Full holding position;
    - 2) After the control has been in operation for 30 minutes; and
    - 3) With the chuck holding the largest load to be used.

## 3.1.1 Connecting Additional Features

SMART-C chuck controls are equipped with two optional features; Current Sensing, and Lockout. These features enable the chuck control to work with external equipment such as machine controls or a PLC.

### 3.1.1.1 Current Sensing

This control is equipped with a current sensing feature that monitors the current flowing to the chuck and indicates when this current has reached a predetermined value. The predetermined value is set by adjusting the variable potentiometer to the desired point and then pressing the residual pushbutton while holding down the variable pushbutton. When the preset value is reached, the Variable indicator light stays on and the current sense relay closes. If the current flowing to the chuck goes below the preset value, the variable light will flash.

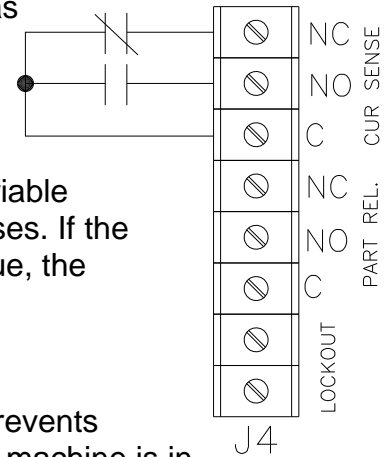

### 3.1.1.2 Lockout

A Lockout feature is supplied with this control, which prevents anyone from accidentally changing the mode while the machine is in operation. In order to use this feature, you must remove jumper “**JP2**” which is located on the Main PC Board.

There are two methods to use this feature:

The first method is to apply a 0V signal (short to ground) when you want someone to be able to change the mode, and remove the 0V signal when you don’t want someone to change the mode. Apply this signal to the terminal labeled “LOCK” on **J5** located on the Main PC Board.

The second method is to apply a 115VAC signal when you want someone to be able to change the mode, and remove the 115VAC signal when you don’t want someone to change the mode. Apply this signal to the terminals labeled “LOCKOUT” on **J4** located on the Main PC Board.

## 4 OPERATING INSTRUCTIONS

### 4.1 Important Facts about Magnetic Holding

Workpiece characteristics must be considered in order to determine the magnetic holding attraction that a magnetic chuck can provide.

This is true for all magnetic chucks because they all operate using the same fundamental laws of physics. Magnetic power is often pictured as lines of magnetic force flowing from north to south pole. Anything that limits the flow of these magnetic lines of force obviously reduces the magnets holding capacity. There are many important factors that limit the flow of these lines of force.

### 4.1.1 Surface Conditions

Magnetic lines of force do not flow easily through air. They need iron in order to flow freely; therefore, anything that creates a space or an air gap between the magnet and the workpiece limits the flow of magnetic lines of force and, thus, reduces the holding capacity of a magnetic chuck.

- **Magnetic Chuck Surface Condition** -- The holding surface of a magnetic chuck must be clean, smooth, flat, and free of nicks or burrs in order to minimize the air gap between the chuck holding surface and the Workpiece. All Walker chucks are designed with soft, low carbon steel magnetic poles in the top plate in order to maximize the holding capacity; therefore, special care must be taken to protect these areas.
- **Workpiece Surface Condition** -- The holding capacity of the chuck will be reduced if certain surface conditions exist. A rough surface finish on the workpiece creates an air gap as also foreign materials like dirt, paint, rust, paper, and rags.

### 4.1.2 Workpiece Thickness

The greater the number of lines of magnetic force flowing from a magnet into the workpiece the greater the effectiveness of the magnetic chuck. The thicker the workpiece, the more lines of magnetic force are able to flow. After a certain thickness of the workpiece, no additional lines of force will flow because the magnet has reached its full capacity.

- Thin workpieces mean less iron available, and thus fewer lines of magnetic force flow from the magnet into the workpiece. Therefore, the chuck holding capacity is reduced.
- Typically, the minimum thickness of a workpiece required to reach full holding capacity is the same as the thickness of the chuck major magnetic steel poles.

### 4.1.3 Portion of the Chuck Surface In Contact With the Workpiece

The full surface of the chuck top plate must be covered by the workpiece to achieve the maximum holding capacity. The surface of the workpiece must contact equal areas of the chuck opposite polarity major magnetic poles to obtain maximum holding force.

#### 4.1.4 Workpiece Material

Low carbon steel such as SAE 1020 steel, are nearly as good conductors of magnetic lines of force as pure iron. However, many other alloys contain non-magnetic materials, which reduce the ability of magnetic lines of force to flow. An alloy such as SAE 300 series stainless steel is almost as poor a conductor of magnetic lines of force as air.

Type 416 stainless steel is considered magnetic, but it contains enough chromium so that a magnet can develop only about one half as much magnetic force as it can on an SAE 1020 steel workpiece. Also, because of the carbon content, the force developed on typical cast iron is less than one half that developed on SAE 1020 steel. (Chilled cast iron further reduces the force to less than one quarter.)

Additional concerns regarding Magnetic Holding should be forwarded to O. S. Walker, Inc.

#### 4.2 Release

(Red Push-Button)

Selecting the Release function initiates an automatic release cycle. During the release cycle, the output voltage produced by the control is reduced from full to zero in a predetermined number of equal pulses (see Figure 4-1). The polarity of these pulses alternately reverses from negative to positive as the magnitude of the voltage decreases. The SMART-B can generate a maximum of sixteen pulses per release cycle, but is set at the factory for eight.

The Release indicator light will flash ON and OFF to show that release is taking place, and will remain ON when the cycle is complete.

The duration of each pulse is automatically controlled. The time between pulses is automatically adjusted by the control for the optimum Release cycle time.

The SMART-C has an adjustment for the number of pulses per Release cycle. This adjustment allows the operator to select the number of pulses it takes to get the fastest, most complete release of a part.

The adjustment for the number of demagnetization pulses per Release cycle is done using the full, residual, release pushbuttons, and the Variable potentiometer. To adjust the number of release pulses, the control must be "at the end of the release cycle". The procedure for adjusting the number of Release pulses is as follows:

1. Hold the Release button down and PRESS the Full button. With some control revisions you may have to press the Full button again after you have let go of the Release button.
2. Using the table below, you can adjust the number of release pulses by turning the Variable adjustment knob.

Number of Release Pulses	1	2	3	4	5	6	7	8	9	10	11	12	13	14	15	16
Variable Lamp/LED								X	X	X	X	X	X	X	X	
Residual Lamp/LED				X	X	X	X					X	X	X	X	
Full Lamp/LED		X	X			X	X			X	X			X	X	
Release Lamp/LED	X		X		X		X		X		X		X		X	

*X indicates lamp/led is on.*

3. Once the number of desired Release pulses has been set, PRESS the Residual button.
4. The control is now ready for operation.

NOTE: THE ADJUSTMENT WILL NOT OPERATE WITHOUT JP1 INSTALLED.ON THE MAIN BOARD.

### ***4.3 Full Holding***

(Green Push-Button)

In the Full holding position, full output voltage is supplied from the control to the chuck as soon as the button is pushed. The indicator light for the Full holding position is illuminated when this function is selected.

**NOTE: Full holding has equivalent holding force to 100% on the Variable holding control knob.**

### ***4.4 Variable Holding***

(White Push-Button)

When the operator presses the Variable holding button, the output voltage of the control can be adjusted from zero to full with the Variable control knob.

A varying amount of Residual hold can be achieved by turning the Variable control knob to zero from its previous holding position without pressing the Residual button.

## **4.5 Residual Holding**

(Yellow Push-Button)

The output of the control is reduced to zero when this function is selected. The control turns the chuck fully ON for a short period of time, thus leaving a recognizable residual holding power in the chuck; this is called True Residual. During this brief pulse, the indicator light, will be ON until another function is selected.

## **4.6 Current Sense**

This control is equipped with a current sensing feature that monitors the current flowing to the chuck and indicates when this current has reached a predetermined value. The predetermined value is set by adjusting the variable potentiometer to its desired point and then pressing the residual push-button while holding down the variable push-button. When the preset value is reached, the Variable indicator light stays on. If the current flowing to the chuck goes below the preset value, the variable light will flash.

## **4.7 Control Protection**

If the control is switched into sudden high power operation with too large a load, the AC fuse may blow before the electronic protective circuits can function.

If the chuck control is overloaded by a short circuit or a chuck too large for this control's rating, the control will sense this condition and will attempt to protect itself by flashing all the system indicator lights, and the control will not respond to any function selection. This will continue until AC power is removed from the control and the problem is corrected.

The logic section of the Main PC Board is protected by a .125A fuse in location F1. This fuse will blow if a problem occurs in the logic section.

If AC power is interrupted while the control is running, the control returns to the mode of operation selected just prior to loss of power. This allows easy resumption of machining after an AC line dropout.

## **4.8 Release Cycle Steps**

The Release Cycle removes residual magnetism in the chuck and workpiece by sending decreasing, alternating pulses of DC voltage through the chuck coils. The amount of demagnetization (DEMAG) depends upon the number of pulses, the length of time that the pulses are applied ( $T = \text{Pulse width}$ ) and the time between pulses ( $t = \text{Off Time}$ ). The first pulse is always negative. The pulse voltages are determined automatically by the chuck control software. The number of demagnetization pulses are adjustable from one to sixteen (1-16). The pulse width and off time are automatically adjusted by the on-board microprocessor. Figure 4-1 on page 4-6.

Figure 4-1 Release Cycle Voltage vs. Release Cycle Time

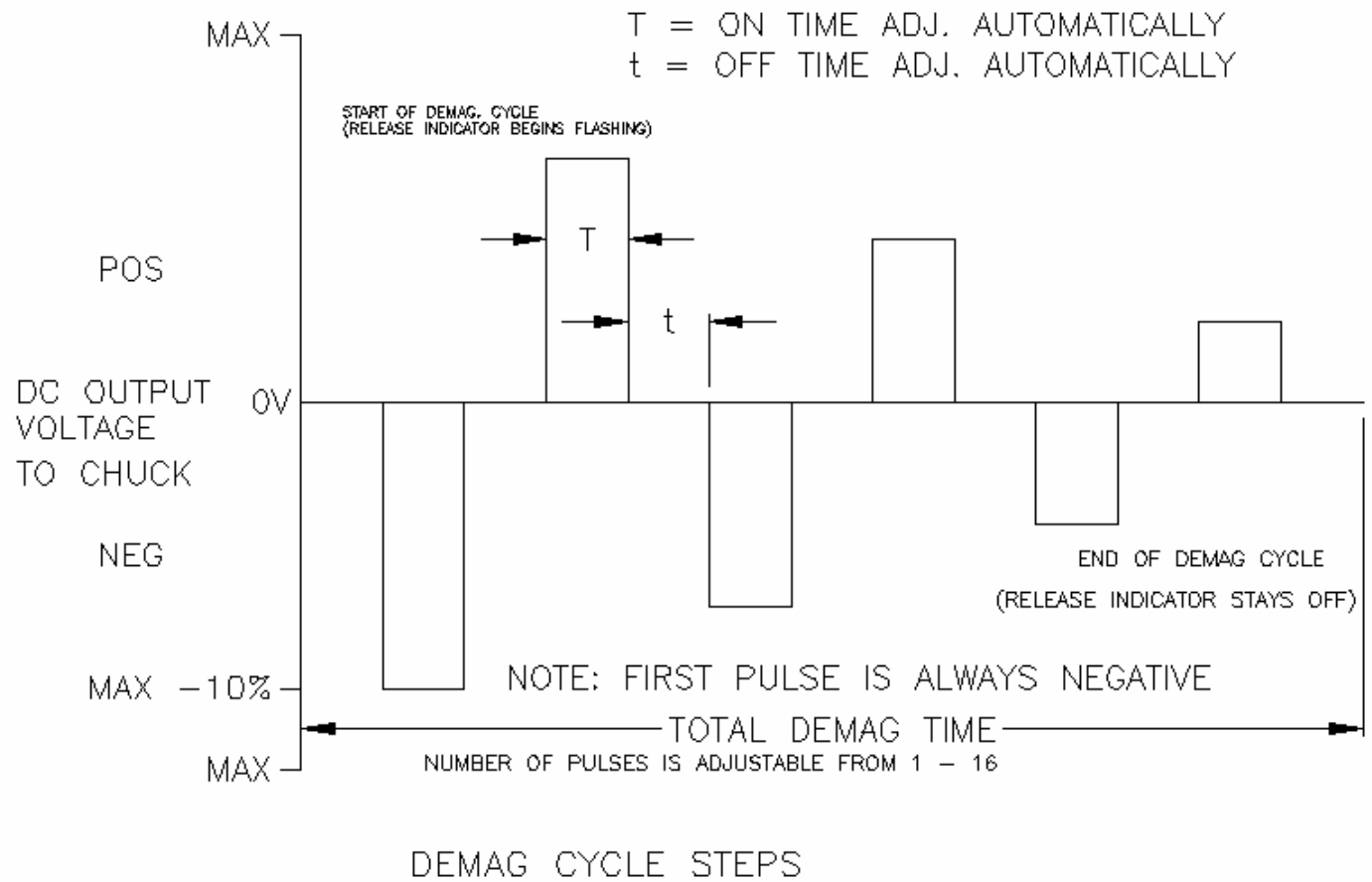

## 4.9 Grounding & Shielding

# WARNING

All electrical chassis must be connected to a proper electrical ground.

The control's internal circuit ground is connected to the AC safety ground (the green or green/yellow wire in the AC line cord). The base of the chuck is to be grounded to this point, as well as, through the ground wire of the DC chuck cable. All electrical chassis must be safety grounded.

The chuck control's DC power output leads **MUST BE SEPARATELY ROUTED** from other 115V level power leads in the machine. They must not be routed in the same wire bundle with 400V or other high voltage leads. If the control has LOW VOLTAGE signal leads wire through the machine, these **MUST BE SEPARATELY ROUTED** in their own SHIELDED WIREWAY and the shield grounded to the machine chassis. Low voltage signals must not be routed with high voltage or high power cables through any part of the machine, or electromagnetic interference may result.

## 4.10 Control Output Voltage

The DC voltage for the magnet is connected across terminals 2 and 3 on J8. This voltage may be measured across these terminals and can vary from 0-115VDC. It may also be measured at the female DC output connector.



## 5 INSPECTION & MAINTENANCE

### 5.1 Daily Inspection

- Check the physical condition of the power cords, indicating lamps, switches, and the control enclosure. If any deficiencies are observed, contact your supervisor or O.S. Walker.
- Check the integrity of the enclosure by inspecting for dust, debris, and fluid. Make necessary repairs.
- Keep the outside of the enclosure free of dust and debris.

### 5.2 Having a Problem with your Chuck Control?

Problem	Probable Cause	Solution
1. All the remote unit lights are flashing.	The load is drawing excessive current and the control unit has protected itself by disabling all operating modes.	<b>BEFORE PROCEEDING, DE-ENERGIZE THE CONTROL UNIT.</b>
		a) Verify the chuck power rating does not exceed the control's power rating.
		b) Disconnect the chuck from the control unit and verify that the chuck's coil windings are not shorted.
		c) Repair/replace where required.
		d) With the load disconnected, re-energize equipment and cycle through all operating modes, verifying proper operation.
		e) Repeat step d. with the load reconnected.
		f) Having successfully completed the above and unit does not function properly, contact O.S. Walker, Inc.
2. None of the control unit lights are illuminated and it does not respond to any operating mode	Input voltage is too low or wired incorrectly. Remote unit is not properly wired.	a) Verify the input voltage to the control unit (see Installation section 3).
		<b>BEFORE PROCEEDING, DE-ENERGIZE THE CONTROL UNIT.</b>
		b) Verify that all fuses are good (see Standard Interface Diagram section 5.3 for location). Use only exact replacement fuses to avoid damaging unit or causing a safety hazard.
		c) Verify the wiring between the control unit and the remote unit (see Standard Interface Diagram section 5.3).
		d) Having successfully completed the above and the unit does not function properly, contact O.S. Walker, Inc.

<p>3. The fuse in the control unit blows when any of the control modes are selected.</p>	<p>Excessive current draw is causing fuse to blow before electronic protective circuits have time to react.</p>	<p><b>BEFORE PROCEEDING, DE-ENERGIZE THE CONTROL UNIT.</b></p>
		<p>a) Visually inspect chuck cable and connections for pinches or other damage.</p>
		<p>b) Check chuck cable and connections for shorts with ohmmeter.</p>
		<p>c) Replace any questionable equipment.</p>
		<p>d) Use only exact replacement fuses to avoid damaging the unit or causing a safety hazard.</p>
		<p>e) Re-energize equipment and cycle through all operating modes, verifying proper operation, with the load disconnected.</p>
		<p>f) Repeat step e. with the load connected.</p>
		<p>g) Having successfully completed the above and the unit does not function properly, contact O.S. Walker, Inc.</p>

## 5.2.1 Main Pc Board

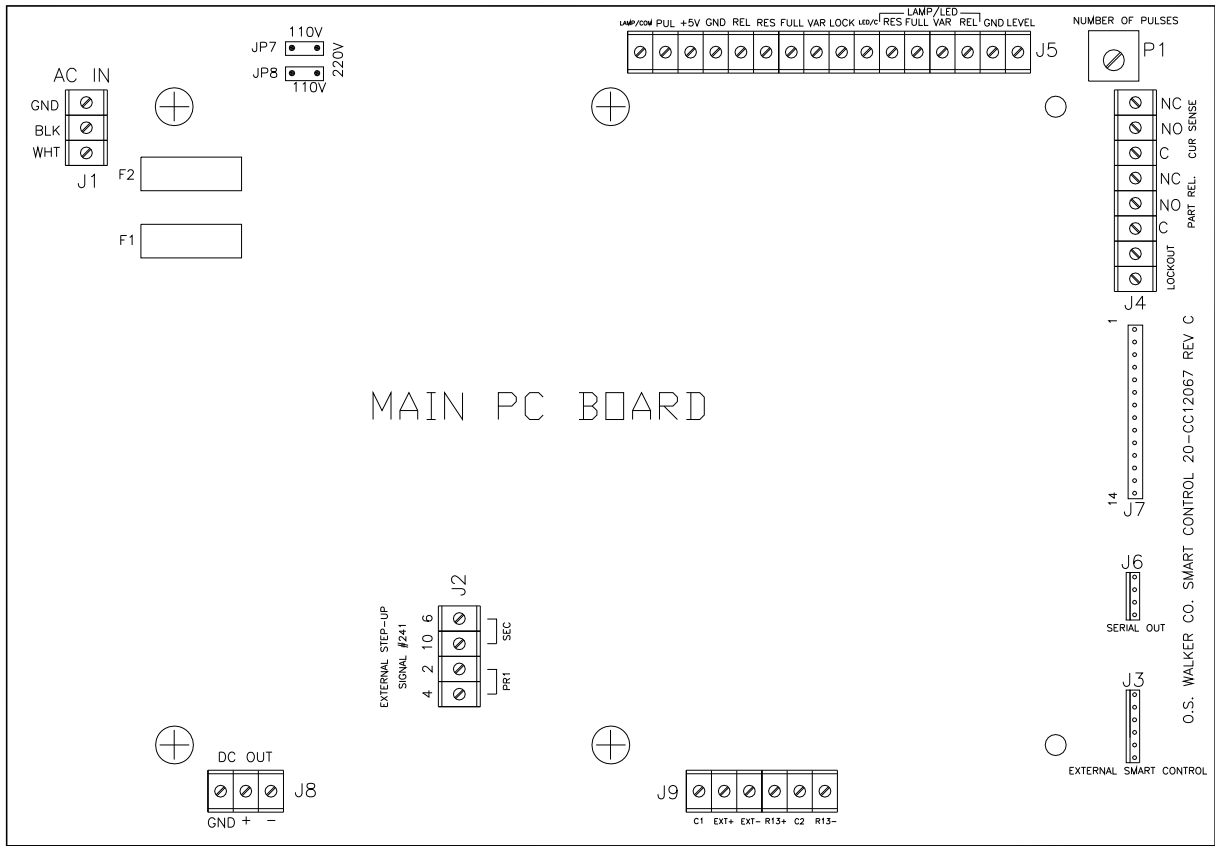

Figure 5-1 Main PC Board

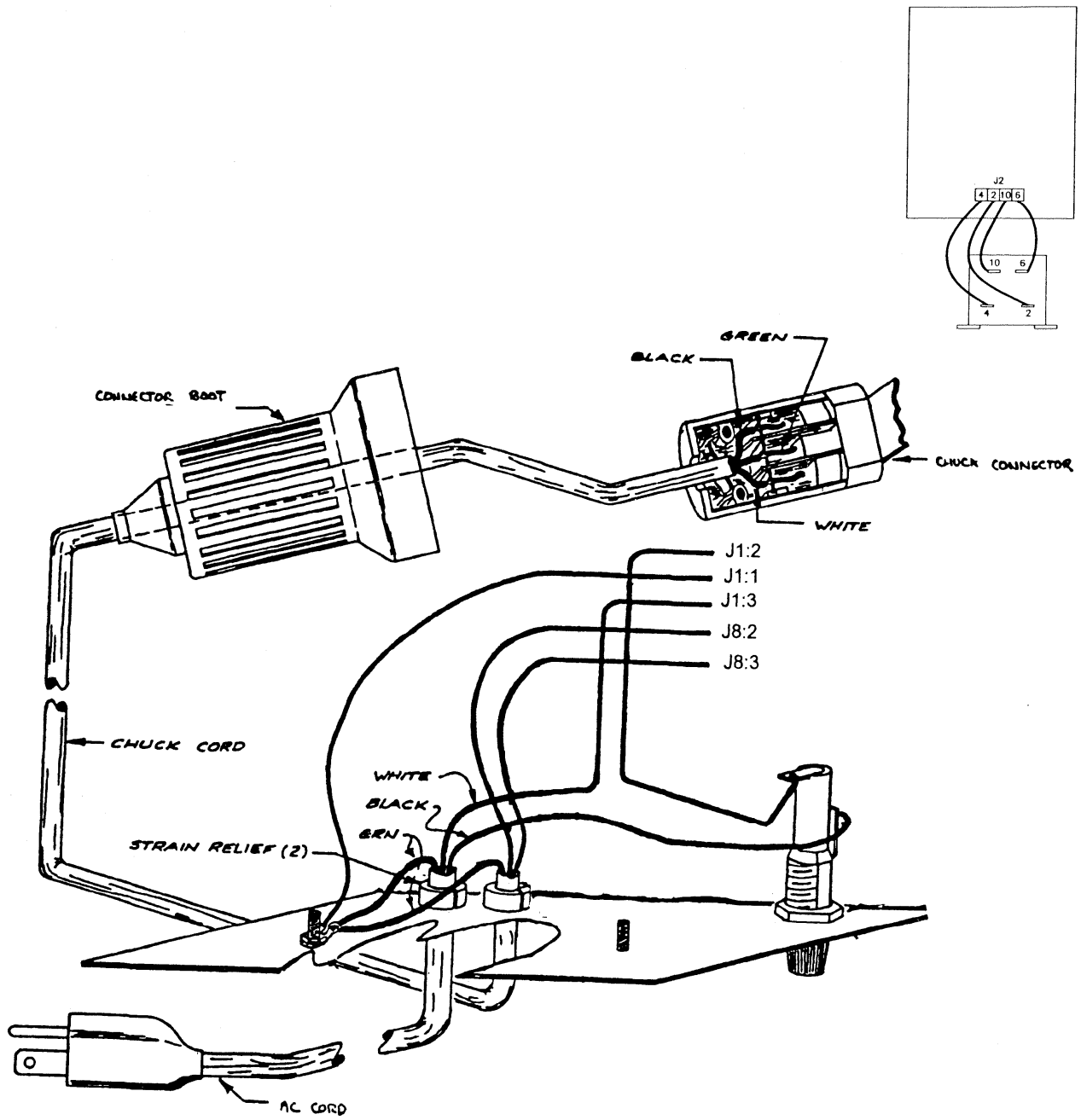

Figure 5-2 Transformer Wiring for Smart-3C & 5C

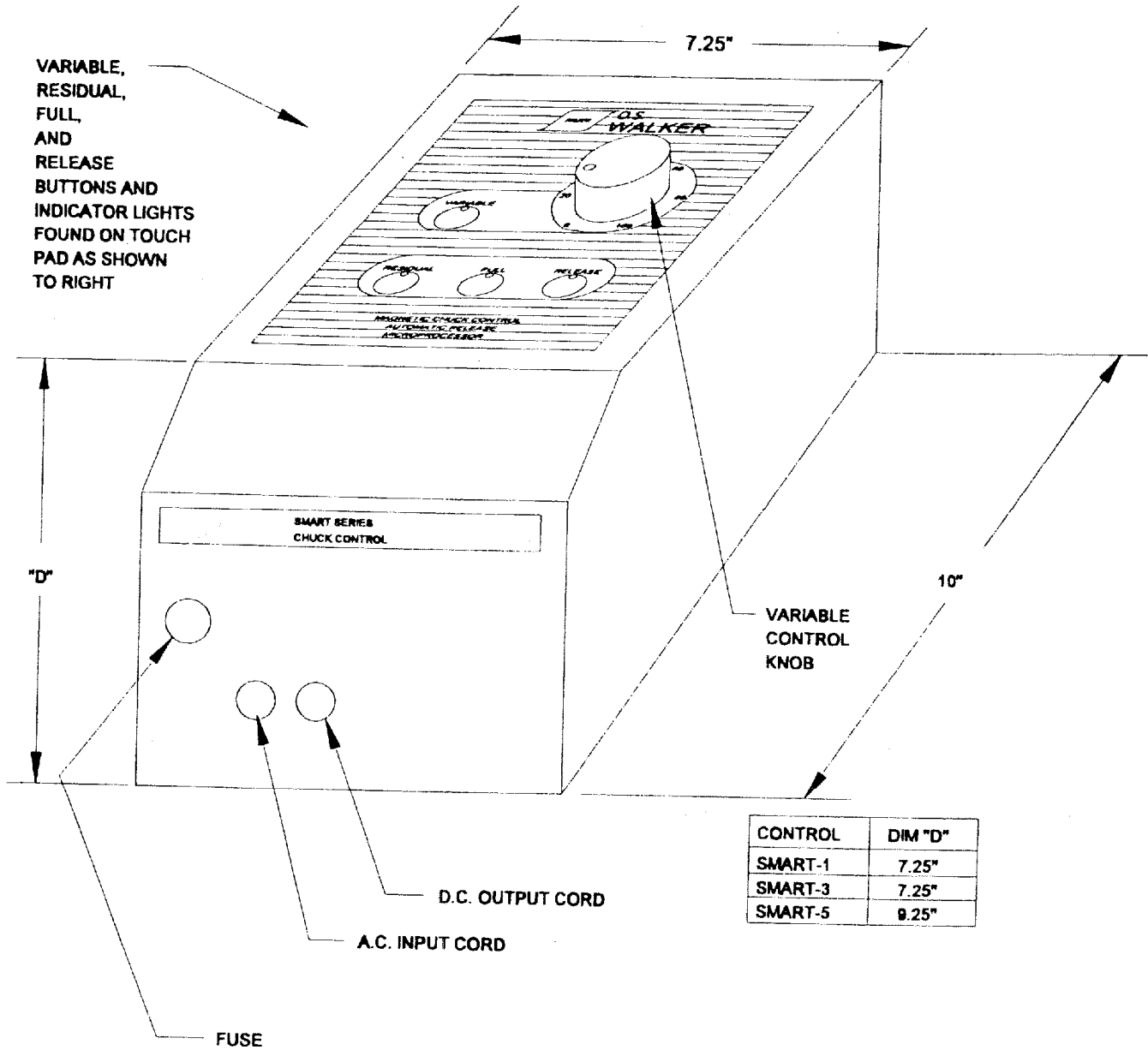
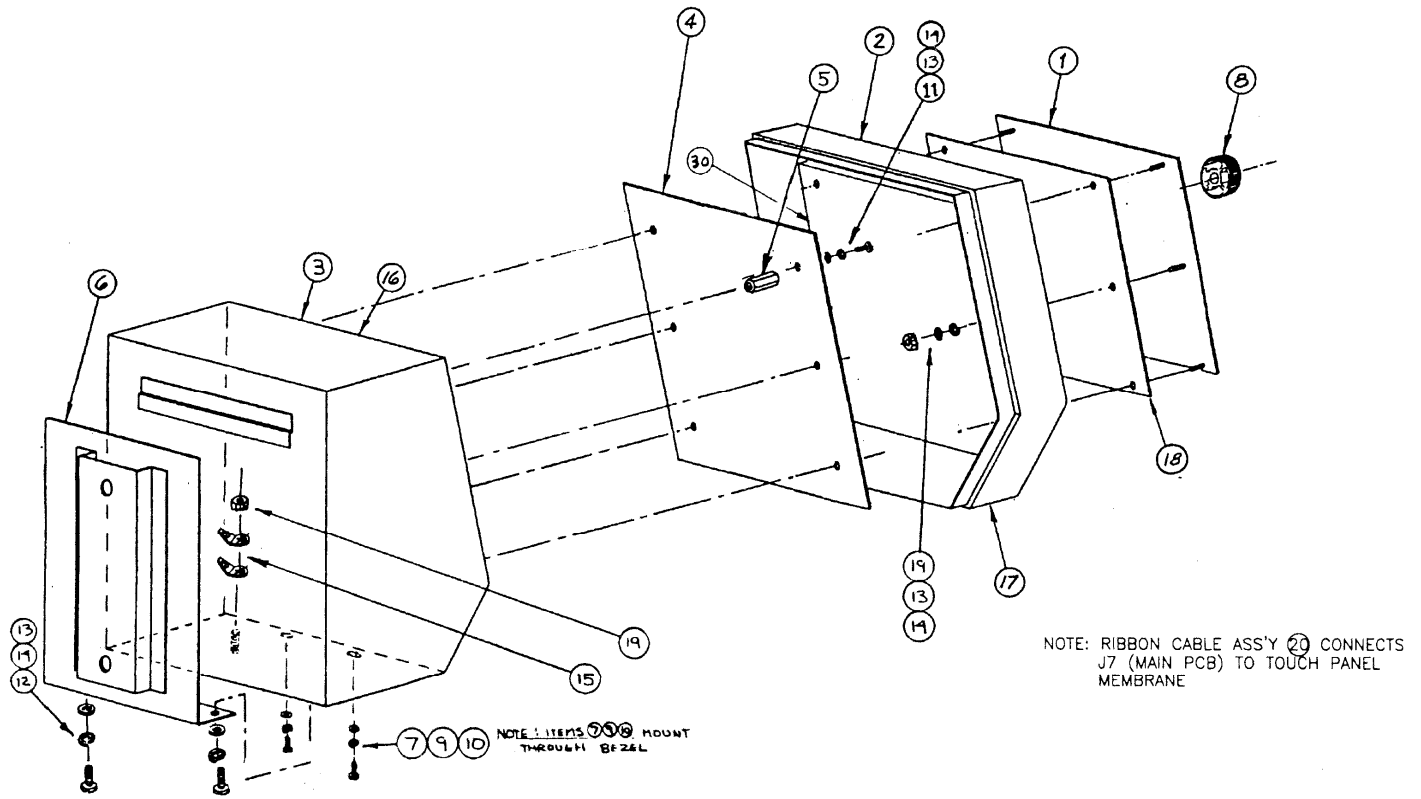

Figure 5-3 Enclosure Dimensions for Smart-C Control



**Figure 5-4 Enclosure Assembly**

## 5.3 Chuck Control Connections

### 5.3.1 Model SMART-C

**Table 5-1 Connector J8 (Main P.C. Board)**

1	GND
2	CHUCK +DC
3	CHUCK -DC

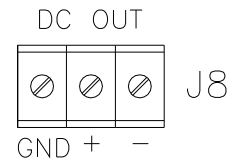

**Table 5-2 Connector J1 (Main P.C. Board)**

1	GND
2	AC HOT
3	AC NEUTRAL

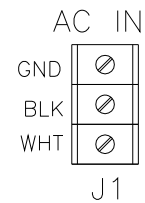

**Table 5-3 Connector J4 (Main P.C. Board)**

J4:1	Lockout Signal
J4:2	Lockout Common
J4:3	
J4:4	
J4:5	
J4:6	Current Sense Common
J4:7	Current Sense NO
J4:8	Current Sense NC

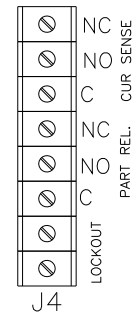

### 5.3.2 Adjustments

Number of Release Pulses (1-16) - Set to 8 pulses at factory (see Release 4.2)

## 6 REPLACEMENT PARTS LIST

### 6.1 SMART-C Controls

Table 6-1 Replacement Parts List

DESCRIPTION	PART NUMBER		
	SMART 1C	SMART 3C	SMART 5C
Main PC Board	39-DD14401	39-DD14329	39-DD14329
Fuse F1 (panel)	18-1124	18-1219	18-1219
Transformer (T2)	N/A	12-0267	12-0267
Ribbon Cable	10-5418	10-5418	10-5429
Switch Panel Membrane Assembly	56-DD14591	56-DD14591	56-DD14591

\* Walker replacement parts may be installed by a **\*\*Designated Person**.

**\*\* Designated Person** - A person selected or assigned by the employer as being competent to replace specific parts listed in this manual and is able to verify the proper functioning of the specific replacement parts and the entire product after the completion of the installation.



## **7 RETURN AND REPAIR INSTRUCTIONS**

For warranty and non-warranty repairs on any part of your chuck system, contact O.S. Walker Company TOLL FREE at 1-800-W-MAGNET. A return authorization number will be issued along with any applicable packaging and shipping instructions. After receipt of the components to be repaired, O.S. Walker Company will perform an inspection and provide an estimate of the repair costs at no charge to the customer. Authorization from the customer must be obtained by O.S. WALKER Company before repairs are made. Transportation charges, both to and from the factory, are the sole responsibility of the customer.

**FOR FAST RESPONSE, CALL 1-800-W-MAGNET**



**O.S. WALKER**

Rockdale Street, Worcester, MA 01606  
(508)-853-3232 FAX (508)-852-8649  
3508 Glenridge Drive, Chino Hills, CA 91709  
(909)-597-4785 FAX (909)-597-0581  
901 Arvin Avenue, Stoney Creek, Ontario, L8E5N9 Canada  
(905)-643-3338  
In Canada: 1-800-267-4678 FAX (905)-643-6111

[www.walkermagnet.com](http://www.walkermagnet.com)

e-mail: [info@walkermagnet.com](mailto:info@walkermagnet.com)