

OPERATOR'S MANUAL AND SAFETY INSTRUCTIONS

WITH INSPECTION AND MAINTENANCE INSTRUCTIONS

NEO Permanent Lifting Magnets

**Models: NEO-125, NEO-250, NEO-500, NEO-1000,
NEO-2000, NEO-HV-250, NEO-HV-500, NEO-HV-1000**

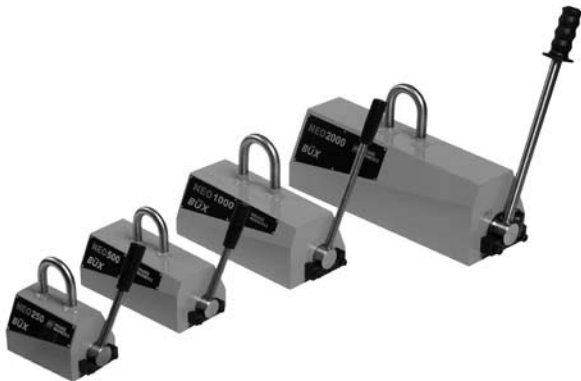

**NEO-125, NEO-250, NEO500,
NEO-1000 & NEO-2000**



NEO-HV-250, NEO-HV-500, NEO-HV-1000



O.S. WALKER

⚠ DANGER

- Always stay clear of the load.
- Never lift loads over people or in close proximity to people.
- Never attempt to operate either of these magnets until you have read and understand this Operator's Manual.

CONTENTS

INTRODUCTION	2
SAFETY INSTRUCTIONS	3
GENERAL SAFETY RULES.....	3
RECOGNIZE SAFETY INFORMATION	4
UNSAFE LIFTING APPLICATIONS FOR YOUR MAGNET	4
WAYS TO AVOID A REDUCTION OF LIFTING CAPACITY	5
ADDITIONAL WARNINGS	5
SAFETY PERSON	5
IMPORTANT FACTS FOR THE OPERATION OF LIFT MAGNETS	6
RECOMMENDED LIFTING PROCEDURES	10
GUIDELINES FOR THE REDUCTION OF THE RATED LIFTING CAPACITY	11
NEO-125 LIFTING GUIDELINES (PLATE)	12
NEO-125 LIFTING GUIDELINES (ROUND BARS).....	13
NEO-250 LIFTING GUIDELINES (PLATE)	14
NEO-250 LIFTING GUIDELINES (ROUND BARS & PIPES).....	15
NEO-500 LIFTING GUIDELINES (PLATE)	16
NEO-500 LIFTING GUIDELINES (ROUND BARS & PIPES).....	17
NEO-1000 LIFTING GUIDELINES (PLATE)	18
NEO-1000 LIFTING GUIDELINES (ROUND BARS & PIPES).....	19
NEO-2000 LIFTING GUIDELINES (PLATE)	20
NEO-2000 LIFTING GUIDELINES (ROUND BARS & PIPES).....	21
INSPECTION AND MAINTENANCE INSTRUCTIONS	22
EVERY LIFT	22
DAILY.....	22
WEEKLY	22
SPECIFICATION & SPARE PARTS LIST	23
NEO-HV 250, NEO-HV 500, NEO-HV 1000	24
HV INSPECTION AND MAINTENANCE	27
DAILY	27
WEEKLY	27
ANNUALLY	27
HV SPARE PARTS LIST	28

INTRODUCTION

Thank you for purchasing this O.S. Walker Product. If used and maintained properly, it should serve you for many years. Thousands of Walker lift magnets are in service today doing safe, fast, and efficient magnetic material handling applications. It is often the only way for one person to load, transport, and unload material.

Walker Products have proven to be among the best designed and safest in our industry. However, used improperly, any **NEO or NEO-HV** lifting magnet can be rendered inefficient and unsafe. Therefore, it is absolutely essential that anyone who uses this lifting magnet and is responsible for its application be trained on how to use it correctly.

READ THIS MANUAL CAREFULLY AND WATCH THE SAFETY VIDEO TO LEARN HOW TO OPERATE AND MAINTAIN YOUR MAGNET. FAILURE TO DO SO COULD RESULT IN SERIOUS INJURY OR DEATH, TO YOURSELF AND PEOPLE IN THE AREA.

THIS MANUAL AND SAFETY VIDEO SHOULD BE CONSIDERED A PERMANENT PART OF YOUR MAGNET AND SHOULD ALWAYS BE AVAILABLE TO ALL OPERATORS AND REMAIN WITH THE MAGNET IF IT IS RE-SOLD.

Additional copies of this OPERATOR'S manual ARE AVAILABLE. JUST CALL 1-800-962-4638 AND REQUEST ADDITIONAL COPIES OF MANUAL #37-DD14493.

SAFETY INSTRUCTIONS

GENERAL SAFETY RULES

Danger always exists when loads are transported by lifting devices, especially when the equipment is not being used properly or is poorly maintained. Because accidents and severe bodily injury or death can result, special safety precautions apply to the operation, inspection, and maintenance of the Walker Lift Magnets.

Following these simple rules can help to avoid lifting accidents:

⚠ DANGER

- **Always** stay clear of the load.
- **Never** lift loads over people or in close proximity to people.
- **Never** attempt to operate this magnet until you read and understand the Operator's Manual.
- **Never** use this magnet to lift, support or transport people.
- **Never** leave any lifted load unattended.
- **Never** lift more than one work piece at a time with this magnet.
- **Always** make sure that the supporting structure and load attaching devices (i.e. crane, chains and hook) are rated to support the weight of the magnet and load.
- **Always** make sure that the load's weight and dimensions are within the Magnet's Lifting Guidelines. These Guidelines are located in the Operator's Manual.
- **Always** let those near you know that a lift is to begin.

Remember, proper lifting knowledge and techniques are the responsibility of the operator. Be sure to read and understand the instructions and safety warnings contained in this manual before using your lifter.

If you do not understand everything in this manual contact O.S. Walker for assistance before using the magnet.

Call 1-800-W-MAGNET

SAFETY INSTRUCTIONS

RECOGNIZE SAFETY INFORMATION



This is the safety alert symbol. When you see this symbol on your magnet or in this manual, be alert to the potential for personal injury. Follow recommended precautions and safe operating practices at all times.



DANGER

Red Background, White Letters

This indicates a situation in which a hazard is imminent and will result in a high probability of serious injury or death.



WARNING

Orange Background, Black Letters

This indicates a potentially hazardous situation, which could result in some probability of serious injury or death.



CAUTION

Yellow Background, Black Letters

This indicates a potentially hazardous situation, which could result in minor injury or moderate injury.

*These Hazard
Signal Words
Deserve your
Full Attention*

UNSAFE LIFTING APPLICATIONS FOR YOUR MAGNET



DANGER

- **Never** lift more than one workpiece at a time with this magnet.
- **Never** lift any castings that do not have a machined flat lifting surface for the magnet. The location of the lifting surface should be such to permit the load to remain level when lifted.

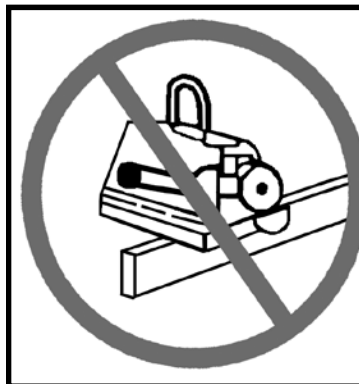

DANGER

- **Never** lift a load by its narrowest dimension.



WARNING

If you have any difficulty lifting a load, **DON'T LIFT IT!**
Call Walker for advice at 1-800-962-4638

SAFETY INSTRUCTIONS

WAYS TO AVOID A REDUCTION OF LIFTING CAPACITY

DANGER

To Avoid any Reduction of Lifting Capacity:

- The lifting surfaces of the magnet and the area of the load where the magnet will be located must be clean, smooth, flat and free of nicks and burrs.
- The full area of the magnet's lifting surface must be in contact with the load.
- The load must be at least 2.5" (64 mm) thick.
- The load must be low carbon steel such as AISI 1020.
- The magnet's lifting surface must stay level and the contacting surface of the load remain flat.
- The temperature of the magnet and/or the load must not be greater than 110°F (43°C).
- The control actuator must be fully in the "on" or "lift" position.
- Repair of this magnet should only be done by the O. S. Walker Co. or a Qualified Person.*
- If you have any difficulty lifting a load, DON'T LIFT IT! Call O.S. Walker for advice at 1-800-962-4638.

ADDITIONAL WARNINGS

WARNING

- **Never** lift loads with any dimension greater than those shown in the LIFTING GUIDELINES.
- **Never** operate damaged or malfunctioning magnets.
- **Never** remove or damage Operating and Warning labels.
- **Persons** using pacemakers or other medical devices should not use this magnet until they have consulted with their physician.

WARNING

- Disassembly or repair of this magnet can result in reduced holding power and/or cause an unsafe condition. Therefore, anytime the magnet is disassembled beyond the parts list shown in this manual, the magnet must be re-tested for breakaway force in accordance with the test described in ANSI/ASME B30.20.
- Modification of any operating mechanism or structure of this magnet can reduce the magnet's effectiveness and/or cause an unsafe condition.
- Repair or modification of this magnet should only be done by O.S. Walker or a Qualified Person.*

SAFETY PERSON

O.S. Walker recommends that a person be assigned to review all magnetic handling applications for these magnets to ensure that safe practices and procedures are being followed.

* **Qualified Person** - A person who by extensive knowledge, training and experience, has successfully demonstrated the ability to solve or resolve problems related to Walker lifting magnets. (Walker replacement parts may be installed by a ****Designated Person**.)

** **Designated Person** - A person selected or assigned by the employer as being competent to replace specific replacement parts listed in this manual and is able to verify the proper functioning of the specific replacement parts and the entire product after the completion of the installation.

IMPORTANT FACTS FOR THE OPERATION OF LIFT MAGNETS

LOAD CHARACTERISTICS OTHER THAN JUST WEIGHT MUST BE CONSIDERED IN ORDER TO DETERMINE THE LOAD THAT ANY MAGNET CAN LIFT.

This statement is true for all lifting magnets because they all operate using the same fundamental laws of physics. Magnetic power is often pictured as lines of magnetic force flowing from north pole to south pole. Anything that limits the flow of these magnetic lines of force obviously reduces the magnet's lifting capacity. There are many important factors, which limit the flow of these lines of force.

1. SURFACE CONDITIONS

Magnetic lines of force do not flow easily through air. They need iron in order to flow freely; therefore, anything that creates a space or an air gap between a magnet and the load limits the flow of magnetic lines of force and, thus, reduces the lifting capacity of a magnet.

- **MAGNET'S LIFTING SURFACE CONDITION** — The lifting surfaces of a magnet must be clean, smooth, flat and free of nicks and burrs to minimize the air gap between a magnet and the load. This magnet has been designed with soft, low carbon steel lifting surfaces in order to maximize the lifting capacity; therefore, special care must be taken to protect these surfaces. Follow the Inspection Instructions in this manual. Attaching or welding other materials to the lifting surfaces in order to reduce wear should not be done with this magnet because it will reduce the lifting capacity.
- **LOAD SURFACE CONDITION** — Paper, dirt, rags, rust, paint, and scale act the same as air. Also, a rough surface finish on the load creates an air gap between the magnet and load. Any of these conditions will reduce the magnet's lifting capacity.

2. LOAD THICKNESS

The greater the number of lines of magnetic force flowing from a magnet into the load, the greater the effectiveness of the magnet. The thicker the load, the more lines of magnetic force are able to flow. After a certain thickness of load, no additional lines of force will flow because the magnet has reached its full capacity.

- Thin material (load) means less iron available, and thus fewer lines of magnetic force flow from the magnet into the load. Therefore, the lifting capacity of the magnet is reduced. In some cases, the magnet will attract more than one thin plate of material when set on a stack of thin plates. **DO NOT LIFT** more than one plate at a time since the lower plate may not be held sufficiently.
- The lifting guidelines provide the user with what minimum thickness of load is required to reach full lifting capacity. Below such thickness of load, the user must accept the reduced lifting capacity of the magnet as shown in the guidelines.

3. LOAD ALLOY

Low carbon steels, such as AISI 1020 steel, are nearly as good conductors of magnetic lines of force as pure iron. However, many other alloys contain non-magnetic materials, which reduce the ability of magnetic lines of force to flow into the load. An alloy such as AISI 300 series of stainless steel is almost as poor a conductor of magnetic lines of force as air.

- Type 416 stainless steel is considered magnetic, but it contains enough chromium so that a magnet can develop only one-half as much force on a type 416 stainless steel load as it can on a AISI 1020 steel load. Also, because of the carbon content, the force developed on cast iron is less than one-half of that developed on AISI 1020 steel. (Chilled cast iron further reduces the force to less than one-quarter.)

4. LOAD LENGTH OR WIDTH

As the length or width of a load increases, it ceases to remain flat when lifted and the edges begin to droop. This drooping or sagging of the load can create an air gap between the load and the magnet. This is called peel. If this occurs, the lifting capacity of the magnet is greatly reduced.

For plate lifting, where drooping often occurs, rectangular shaped magnets must be positioned so that the length of the magnet is parallel to the width of the load.

5. POSITION OF MAGNET'S LIFTING SURFACE

As the position of the magnet's lifting surface changes from horizontal to vertical, the lifting capacity of the magnet decreases. When the magnet's lifting surfaces are vertical, the lifting capacity of the magnet is minimum and dependent upon the coefficient of friction between the magnet's lifting surface and the load.

6. PORTION OF MAGNET SURFACE IN CONTACT WITH LOAD

The full surface of the magnet must contact the load if the magnet is to achieve rated lift capacity.

7. LOAD TEMPERATURE

The temperature of the load can cause damage to the magnet and, if high enough, can even change the magnetic characteristics of the load. For Standard Lift Magnets, Walker should be consulted if the load or air temperature exceeds 110° F (43° C).

SAFETY

FOR FAST, EASY LIFTING WITH YOUR WALKER

NEO-125, NEO-250, NEO-500,

NEVER attempt to turn the magnet on or off in the "Lifting Guidelines" section of this on loads that are too thin will result in the

1 NEVER

attempt to operate this lift magnet until you read and understand the OPERATOR'S MANUAL & SAFETY INSTRUCTIONS for the NEO-125, NEO-250, NEO-500, NEO-1000 AND NEO-2000 Lifting Magnets.

2



Check the condition of the magnet prior to every lift. WIPE clean the bottom of the magnet and the area on the load where the magnet will be located. File away burrs.

5

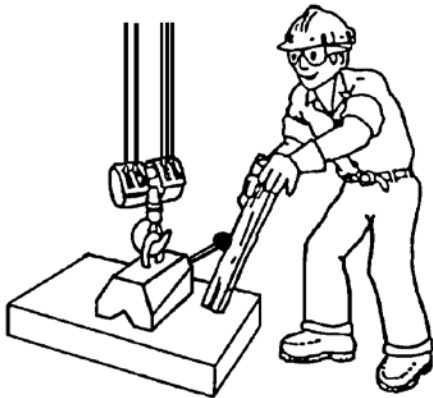

Check to be sure no one is near the load to be lifted. Inform others in the area that a lift is to begin. Lift the load 2 to 3 inches (50 to 75 mm) and then jar the load to insure that adequate holding power is available.

ALWAYS STAY CLEAR OF THE LOAD.

6

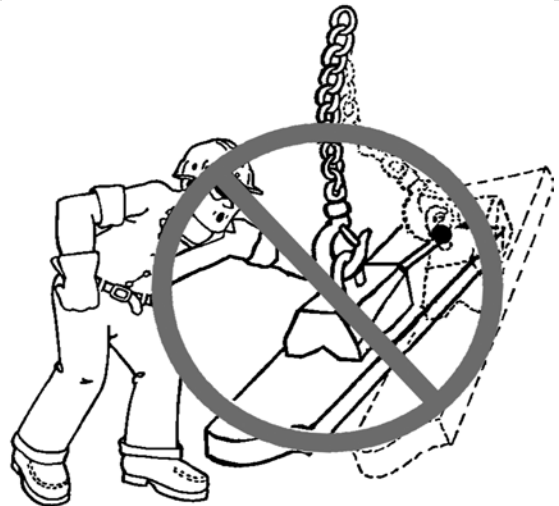

Lift and move the load SMOOTHLY. Avoid jarring and swinging the load while it is in transit. KEEP THE LOAD LEVEL. NEVER let the load come in contact with any obstruction.

If you have any difficulty lifting a load, DON'T LIFT IT. Ask your supervisor for help or call

8 O.S. Walker Co., Inc., for advice at 1-800-W-MAGNET

When working in an area using lifting magnets, wear safety glasses, work gloves, steel-toed shoes and a safety hat.

RULES

LIFT MAGNETS MODELS: NEO-1000 & NEO2000

unless the magnet is in contact with a load of a thickness equal to those listed manual. Attempting to energize or de-energize this magnet without a load or high probability of personal injury due to handle spring back.

3

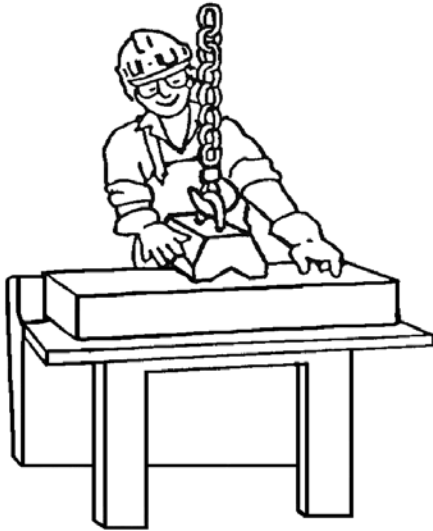

Position the magnet so the load remains level.

4

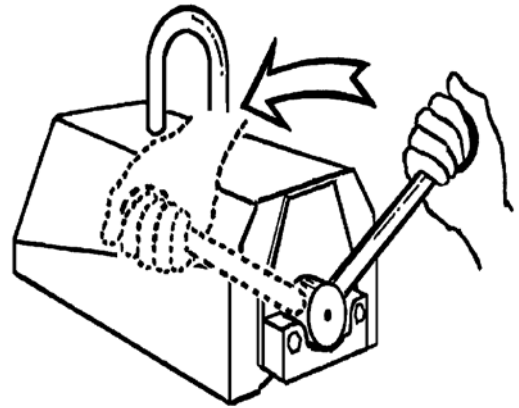

To energize magnet, grip the handle firmly and pull the handle from its locked position. Turn the handle to the "ON" position. Then be sure to return the handle to the FULLY LOCKED POSITION. Release the handle.

7

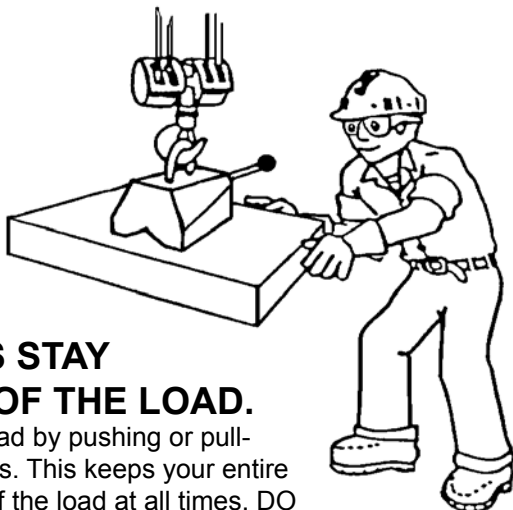

ALWAYS STAY CLEAR OF THE LOAD.

Guide the load by pushing or pulling the edges. This keeps your entire body clear of the load at all times. DO NOT guide the load by pushing or pulling the Magnet. NEVER get in a position where you could get hit with load if it dropped.

8

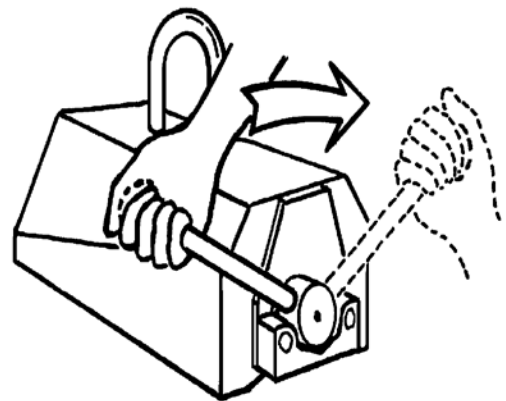

Carefully set the load down. To release the load, grip the handle firmly, unlock the handle shaft, and turn the handle to the "OFF" position. Lift the magnet slightly to be sure the load has been released.

CAUTION

NEVER re-energize the magnet until it has been placed in contact with the load to be lifted. Prematurely energizing the magnet could cause unwanted materials to be attracted to the magnet. **PERSONAL INJURY MAY RESULT.**

RECOMMENDED LIFTING PROCEDURES

■ SAFETY HOOK LATCH

Always use a safety hook latch on your crane hook to hold your magnets.



■ STAY CLEAR OF THE LOAD

Guide the load by pushing or pulling the edges of the load. Keep your entire body clear of the load at all times.

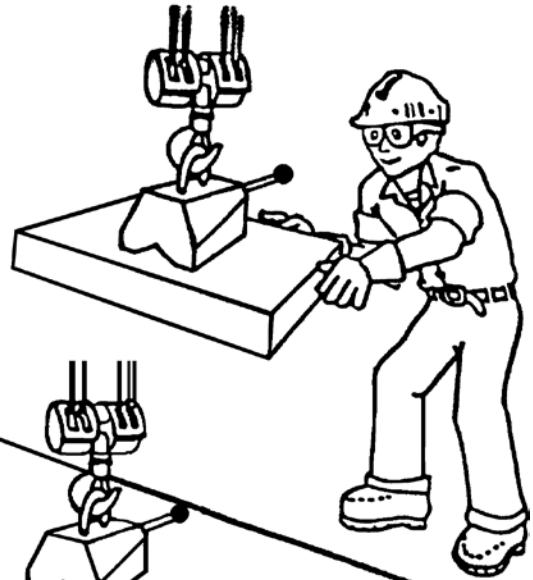

■ PLATE LIFTING

On plates less than 1 1/2" (38mm) thick, position the magnet length so that it is parallel to the width of the plate. Never lift any plate less than 1/4" (6mm) thick. (See Important Facts 2 & 4).

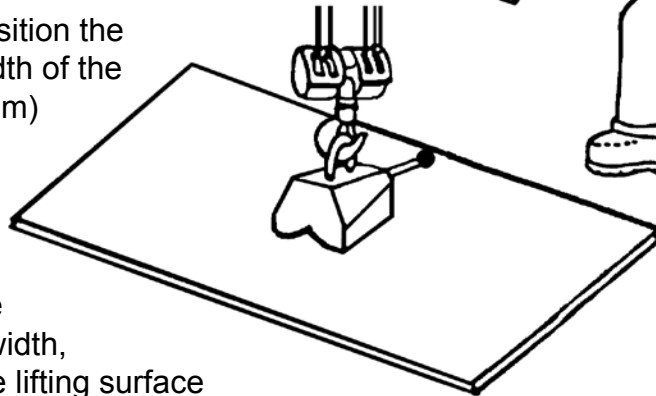

■ BAR LIFTING

When the load is thicker than 1 1/2" (38mm), and the load width is less than the magnet length, but wider than the magnet width, position the magnet length so that the entire lifting surface of the magnet is in contact with the load.

When the load width is less than the magnet width, position the magnet so you get the maximum, and equal amounts of each of the magnets pole area in contact with the load.



ALWAYS MAKE SURE THAT THE LOAD'S WEIGHT AND DIMENSIONS ARE WITHIN THE MAGNET'S LIFTING GUIDELINES.

UNSAFE LIFTING APPLICATIONS FOR YOUR NEO-125, 250, 500, 1000, AND 2000 LIFTING MAGNETS

⚠ DANGER

- **Never** lift more than one workpiece at a time with this magnet.
- **Never** lift any castings that do not have a machined flat lifting surface for the magnet. The location of the lifting surface should be such to permit the load to remain level when lifted.

⚠ DANGER

- **Never** lift a load by its narrowest dimension.

⚠ WARNING

If you have any difficulty lifting a load, DON'T LIFT IT!
Call Walker for advice at 1-800-962-4638

GUIDELINES FOR THE REDUCTION OF THE RATED LIFTING CAPACITY

CAUTION: Each Walker magnet model is rated for a different weight limit, and the load characteristics will affect the lifting capacity of the magnets. The lifting guidelines for the various models are shown on the following pages.

- The Lifting Guidelines charts show the effect of air gap, load thickness, load length, and load width on lifting capacity. As the thickness of the load decreases, so does the rated lifting capacity of the magnet. The tables show the maximum weight or load size, which can be lifted for each thickness under varying air gap conditions. **DO NOT EXCEED EITHER THE MAXIMUM WEIGHT OR SIZE FOR EACH THICKNESS.**
- Each value shown on the Lifting Guidelines charts is for AISI 1020 steel, and any increase in alloy content will result in further reduction of the lifting capacity of the magnet.

THIS TABLE PROVIDES SOME REDUCTION FACTORS FOR MATERIAL OTHER THAN AISI 1020 STEEL	
Reduction Factors for Materials Other than AISI 1020 Steel	
Materials	REDUCTION FACTOR
Cast Steel	0.90
3% Silicon Steel	0.80
AISI 1095 Steel	0.70
416 Stainless Steel	0.50
Cast Iron (non-chilled)	0.45
Pure Nickel	0.10
For Other Materials Consult O.S. Walker	

PLATE

Rated lift Capacity (For these materials) = **Reduction Factor** multiplied by **Maximum Load Value** (For 1020 Steel) from Lifting Guidelines (plate). See pages 12, 14 & 16.

Example: Lifting AISI 1095 STEEL, ½" thick, ROUGH machined flat surfaces (use .020" air gap) with a Model NEO-250 magnet.

Rated Lift Capacity = 0.70 multiplied by 160 = 112 pounds.

ROUND BARS & PIPES

Rated lift Capacity (For these materials) = **Reduction Factor** multiplied by **Maximum Load Value** (For AISI 1020 Steel) from Lifting Guidelines (round bar & pipe). See pages 13, 15 & 17.

Example: Lifting CAST IRON, (non-chilled), 8" diameter solid round bar, CLEAN AND SMOOTH GROUND surfaces (use 0" air gap) with a Model NEO-500 lifting magnet.

Rated Lift Capacity = 0.45 multiplied by 38" = 17.1".

WARNING

If you have any difficulty lifting a load, DON'T LIFT IT!
Call Walker for advice at 1-800-962-4638

NEO-125 LIFTING GUIDELINES (PLATE)

Values shown are for maximum rated capacities when operating instructions and warnings are followed.

VALUES ARE BASED UPON AISI 1020 STEEL

Higher alloy steels and other magnetic materials will require further reductions of these rated capacities (See page 11 for the Guidelines for the reduction of the Rated Lifting Capacities.)

NEVER EXCEED EITHER THE MAXIMUM WEIGHT OF SIZE SHOWN FOR EACH LOAD THICKNESS AND TYPE OF SURFACE CONDITION

LOAD THICKNESS Inches	TYPE OF SURFACE CONDITION					
	CLEAN & SMOOTH Similar to a Flat (32 micro-inch RMS) Ground Surface .000" Max. Air Gap †		RUST OR SCALE Similar to a Flat Hot Rolled Steel Surface .010" Max. Air Gap † (.254mm)		IRREGULAR OR ROUGH Similar to a Flat Smooth Cut File .020" Max. Air Gap † (.508mm)	
	Max. Load (lbs.)	Max. Size (in.)	Max. Load (lbs.)	Max. Size (in.)	Max. Load (lbs.)	Max. Size (in.)
*1" (25.4mm)	275 (125kg)	-	165 (75kg)	-	132 (60kg)	-
*5/8" (15.87mm)	212 (96kg)	20 x 60 (.51 x 1.52m)	140 (64kg)	20 x 40 (.51x1.02m)	120 (54kg)	20 x 34 (.51x.86m)
*3/8" (9.525mm)	127 (58kg)	20 x 60 (.51 x 1.52m)	110 (57kg)	20 x 52 (.51x1.32m)	85 (39kg)	20 x 40 (.51x1.02m)
*3/16" (4.762mm)	65 (29kg)	20 x 60 (.51 x 1.52m)	57 (26kg)	20 x 54 (.51x1.37m)	53 (24kg)	20 x 50 (.51x1.27m)
*3/32" (2.381mm)	33 (15kg)	20 x 60 (.51 x 1.52m)	28 (13kg)	20 x 54 (.51x1.37m)	24 (11kg)	20 x 48 (.51x1.22m)

NEVER LIFT ANY LOADS WITH ANY DIMENSION GREATER THAN 60 INCHES (1.5 METERS) OR WITH A THICKNESS LESS THAN 3/32" (2.38 mm)

† Air Gap = nonmagnetic separation between magnet's lifting surface and load.

* Lifting capacity affected by peel and thickness. See notes 2 & 4 in the "Important Facts" and "Recommended Lifting Procedures" (See pages 6, 7 and 10).

NEO-125 LIFTING GUIDELINES (ROUND BARS & PIPES)

Values shown are for maximum rated capacities when operating instructions and warnings are followed.

VALUES ARE BASED UPON AISI 1020 STEEL

Higher alloy steels and other magnetic materials will require further reductions of these rated capacities
(See page 11 for the Guidelines for the reduction of the Rated Lifting Capacities.)

NEVER EXCEED EITHER THE MAXIMUM LENGTH or WEIGHT SHOWN FOR EACH ROUND BAR/PIPE DIAMETER, WALL THICKNESS & TYPE OF SURFACE CONDITION

Round Bar/Pipe Diameter Inches	TYPE OF SURFACE CONDITION					
	CLEAN & SMOOTH Similar to a Flat (32 micro-inch RMS) Ground Surface		RUST OR SCALE Similar to a Flat Hot Rolled Steel Surface .010" Max. Air Gap † (.254mm)		IRREGULAR OR ROUGH Similar to a Flat Smooth Cut File .020" Max. Air Gap † (.508mm)	
	Maximum Length Inches	Maximum Load Pounds	Maximum Length Inches	Maximum Load Pounds	Maximum Length Inches	Maximum Load Pounds
4" (102mm) MAX. DIAM.	24"	88	17"	61	14"	50
3" (76mm)	44"	88	30"	61	24"	50
2" (51mm)	60"	60	54"	50	45"	40

NEVER LIFT ROUND BARS WITH:
 A diameter LESS THAN 2.00 Inches or
 A diameter GREATER THAN 4.00 Inches or
 A length greater than shown in the Lifting Guidelines above
 (Absolute maximum length 60" (1524mm))

† Air Gap = nonmagnetic separation between magnet's lifting surface and load.

NEO-250 LIFTING GUIDELINES (PLATE)

Values shown are for maximum rated capacities when operating instructions and warnings are followed.

VALUES ARE BASED UPON AISI 1020 STEEL

Higher alloy steels and other magnetic materials will require further reductions of these rated capacities (See page 11 for the Guidelines for the reduction of the Rated Lifting Capacities.)

NEVER EXCEED EITHER THE MAXIMUM WEIGHT OF SIZE SHOWN FOR EACH LOAD THICKNESS AND TYPE OF SURFACE CONDITION

LOAD THICKNESS Inches	TYPE OF SURFACE CONDITION					
	CLEAN & SMOOTH Similar to a Flat (32 micro-inch RMS) Ground Surface .000" Max. Air Gap †		RUST OR SCALE Similar to a Flat Hot Rolled Steel Surface .010" Max. Air Gap † (.254mm)		IRREGULAR OR ROUGH Similar to a Flat Smooth Cut File .020" Max. Air Gap † (.508mm)	
	Max. Load (lbs.)	Max. Size (in.)	Max. Load (lbs.)	Max Size (in.)	Max Load (lbs.)	Max Size (in.)
2 1/2" & above (64mm & above)	550 (250kg)	-	360 (165kg)	-	230 (105kg)	-
*1" (25.4mm)	450 (205kg)	48 x 32 (1.2 x .8m)	305 (140kg)	44 x 24 (1.1 X .6m)	205 (95kg)	30 x 24 (.75 x .6m)
*1/2" (12.7mm)	275 (125kg)	48 x 40 (1.2 x 1.0m)	220 (100kg)	48 x 30 (1.2 x .75m)	160 (73kg)	36 x 30 (.9 x .75m)
*3/8 (9.5mm)	170 (77kg)	48 x 32 1.2 x .8m)	130 (60kg)	36 x 32 (.9 x .8m)	107 (49kg)	42 x 24 (1.05 x .6m)
*1/4" (6.4mm)	90 (42kg)	48 x 26 (1.2 x 6.5m)	65 (30kg)	36 x 24 (.9 x .6m)	55 (25kg)	30 x 24 (.75 x .6m)

NEVER LIFT ANY LOADS WITH ANY DIMENSION GREATER THAN 60 INCHES (1.5 METERS) OR WITH A THICKNESS LESS THAN 1/4" (6.4 mm)

† Air Gap = nonmagnetic separation between magnet's lifting surface and load.

* Lifting capacity affected by peel and thickness. See notes 2 & 4 in the "Important Facts" and "Recommended Lifting Procedures" (See pages 6, 7 and 10).

NEO-250

LIFTING GUIDELINES (ROUND BARS & PIPES)

Values shown are for maximum rated capacities when operating instructions and warnings are followed.

VALUES ARE BASED UPON AISI 1020 STEEL

Higher alloy steels and other magnetic materials will require further reductions of these rated capacities (See page 11 for the Guidelines for the reduction of the Rated Lifting Capacities.)

NEVER EXCEED EITHER THE MAXIMUM LENGTH or WEIGHT SHOWN FOR EACH ROUND BAR/PIPE DIAMETER, WALL THICKNESS & TYPE OF SURFACE CONDITION

Round Bar/Pipe Diameter Inches	Pipe Wall Thickness Inches	TYPE OF SURFACE CONDITION					
		CLEAN & SMOOTH Similar to a Flat (32 micro-inch RMS) Ground Surface .000" Max. Air Gap †		CLEAN & SMOOTH Similar to a Flat Hot Rolled Steel Surface .010" Max. Air Gap † (.254mm)		IRREGULAR OR ROUGH Similar to a Flat Smooth Cut File .020" Max. Air Gap † (.508mm)	
		Maximum Length Inches	Maximum Load Pounds	Maximum Length Inches	Maximum Load Pounds	Maximum Length Inches	Maximum Load Pounds
7" (178mm) MAX. DIA.	1/4"	30"	45	21"	32	18"	27
	1/2"	47"	137	35"	102	28"	82
	1"	42"	225	28"	152	19"	102
	SOLID BAR	25"	275	16"	180	10"	115
6" (152mm)	1/4"	35"	45	25"	32	21"	27
	1/2"	56"	137	41"	102	33"	82
	SOLID BAR	34"	275	22"	180	14"	115
5" (127mm)	1/4"	42"	45	30"	32	25"	27
	1/2"	68"	137	50"	102	41"	82
	SOLID BAR	49"	275	32"	180	20"	115
4" (101mm)	1/4"	53"	45	38"	32	32"	27
	1/2"	88"	137	65"	102	52"	82
	SOLID BAR	77"	275	50"	180	32"	115
2 3/8" (60mm) MIN. DIA.	1/4"	95"	45	67"	32	57"	27
	1/2"	137"	137	122"	102	98"	82
	SOLID BAR	137"	170	137"	170	91"	115

NEVER LIFT ROUND BARS OR PIPES WITH:

- A diameter LESS THAN 2.375 Inches or
- A diameter GREATER THAN 7 Inches or
- A wall thickness LESS THAN 1/4" (6.4mm) or
- A length greater than shown in the Lifting Guidelines above
(Absolute maximum length 137" (3500mm))

† Air Gap = nonmagnetic separation between magnet's lifting surface and load.

NEO-500 LIFTING GUIDELINES (PLATE)

Values shown are for maximum rated capacities when operating instructions and warnings are followed.

VALUES ARE BASED UPON AISI 1020 STEEL

Higher alloy steels and other magnetic materials will require further reductions of these rated capacities (See page 11 for the Guidelines for the reduction of the Rated Lifting Capacities.)

NEVER EXCEED EITHER THE MAXIMUM WEIGHT OR SIZE SHOWN FOR EACH LOAD THICKNESS AND TYPE OF SURFACE CONDITION

LOAD THICKNESS Inches	TYPE OF SURFACE CONDITION					
	CLEAN & SMOOTH Similar to a Flat (32 micro-inch RMS) Ground Surface .000" Max. Air Gap †		RUST OR SCALE Similar to a Flat Hot Rolled Steel Surface .010" Max. Air Gap † (.254mm)		IRREGULAR OR ROUGH Similar to a Flat Smooth Cut File .020" Max. Air Gap † (.508mm)	
	Max. Load (lbs.)	Max. Size (in.)	Max. Load (lbs.)	Max Size (in.)	Max Load (lbs.)	Max Size (in.)
2 1/2" & above (64mm & above)	1100 (500kg)	-	825 (375kg)	-	550 (250kg)	-
*1" (25.4mm)	880 (400kg)	72 x 42 (1.8 x 1.05m)	685 (312kg)	60 x 40 (1.5 x 1.0m)	470 (215kg)	60 x 26 (1.5 x .65m)
*1/2" (12.7mm)	395 (180kg)	72 x 36 (1.8 x .9m)	315 (145kg)	60 x 36 (1.5 x .9m)	260 (120kg)	60 x 30 (1.5 x .75m)
*3/8 (9.5mm)	250 (115kg)	48 x 48 (1.2 x 1.2m)	185 (85kg)	48 x 36 (1.2 x .9m)	160 (73kg)	42 x 36 (1.05 x .9m)
*1/4" (6.4mm)	110 (50kg)	48 x 36 (1.05 x .9m)	85 (40kg)	40 x 30 (1 x .75m)	70 (33kg)	36 x 26 (.9 x .65m)

NEVER LIFT ANY LOADS WITH ANY DIMENSION GREATER THAN 72 INCHES (1.2 METERS) OR WITH A THICKNESS LESS THAN 1/4" (6.4 mm)

† Air Gap = nonmagnetic separation between magnet's lifting surface and load.

* Lifting capacity affected by peel and thickness. See notes 2 & 4 in the "Important Facts" and "Recommended Lifting Procedures" (See pages 6, 7 and 10).

NEO-500 **LIFTING GUIDELINES** (ROUND BARS & PIPES)

Values shown are for maximum rated capacities when operating instructions and warnings are followed.

VALUES ARE BASED UPON AISI 1020 STEEL

Higher alloy steels and other magnetic materials will require further reductions of these rated capacities (See page 11 for the Guidelines for the reduction of the Rated Lifting Capacities.)

NEVER EXCEED EITHER THE MAXIMUM LENGTH or WEIGHT SHOWN FOR EACH ROUND BAR/PIPE DIAMETER, WALL THICKNESS & TYPE OF SURFACE CONDITION

Round Bar/Pipe Diameter Inches	Pipe Wall Thickness Inches	TYPE OF SURFACE CONDITION					
		CLEAN & SMOOTH Similar to a Flat (32 micro-inch RMS) Ground Surface .000" Max. Air Gap †		CLEAN & SMOOTH Similar to a Flat Hot Rolled Steel Surface .010" Max. Air Gap † (.254mm)		IRREGULAR OR ROUGH Similar to a Flat Smooth Cut File .020" Max. Air Gap † (.508mm)	
		Maximum Length Inches	Maximum Load Pounds	Maximum Length Inches	Maximum Load Pounds	Maximum Length Inches	Maximum Load Pounds
10" (254mm) MAX. DIA.	1/4"	25"	55	19"	41	16"	35
	1/2"	46"	197	37"	157	30"	130
	1"	55"	440	42"	342	29"	235
	SOLID BAR	24"	550	18"	420	12"	285
8" (203mm)	1/4"	32"	55	24"	42	20"	35
	1/2"	59"	197	47"	157	39"	130
	SOLID BAR	38"	550	29"	420	20"	285
6" (152mm)	1/4"	43"	55	32"	42	27"	35
	1/2"	80"	197	64"	157	53"	130
	SOLID BAR	68"	550	53"	420	35"	285
4" (101mm)	1/4"	66"	55	50"	42	42"	35
	1/2"	126"	197	100"	157	83"	130
	SOLID BAR	154"	550	118"	420	80"	285
2 3/4" (70mm) MIN. DIA.	1/4"	98"	55	75"	42	73"	35
	1/2"	157"	157	157"	157	130"	130
	SOLID BAR	157"	264	157"	264	157"	364

NEVER LIFT ROUND BARS OR PIPES WITH:
 A diameter LESS THAN 2.75 Inches or
 A diameter GREATER THAN 10 Inches or
 A wall thickness LESS THAN 1/4" (6.4mm) or
 A length greater than shown in the Lifting Guidelines above
 (Absolute maximum length 157" (4000mm))

† Air Gap = nonmagnetic separation between magnet's lifting surface and load.

NEO-1000 LIFTING GUIDELINES (PLATE)

Values shown are for maximum rated capacities when operating instructions and warnings are followed.

VALUES ARE BASED UPON AISI 1020 STEEL

Higher alloy steels and other magnetic materials will require further reductions of these rated capacities (See page 11 for the Guidelines for the reduction of the Rated Lifting Capacities.)

NEVER EXCEED EITHER THE MAXIMUM WEIGHT OR SIZE SHOWN FOR EACH LOAD THICKNESS AND TYPE OF SURFACE CONDITION

LOAD THICKNESS Inches	TYPE OF SURFACE CONDITION					
	CLEAN & SMOOTH Similar to a Flat (32 micro-inch RMS) Ground Surface .000" Max. Air Gap †		RUST OR SCALE Similar to a Flat Hot Rolled Steel Surface .010" Max. Air Gap † (.254mm)		IRREGULAR OR ROUGH Similar to a Flat Smooth Cut File .020" Max. Air Gap † (.508mm)	
	Max. Load (lbs.)	Max. Size (in.)	Max. Load (lbs.)	Max Size (in.)	Max Load (lbs.)	Max Size (in.)
3" & above (76mm & above)	2200 (1000kg)	-	1845 (840kg)	-	1415 (645kg)	-
*2" (51mm)	1960 (890kg)	72 x 48 (1.8 x 1.2m)	1670 (760kg)	72 x 40 (1.8 x 1.0m)	1320 (600kg)	72 x 32 (1.8 x .8m)
*1" (25.4mm)	1175 (535kg)	84 x 48 (2.1 x 1.2m)	1045 (475kg)	76 x 48 (1.9 x 1.2m)	900 (410kg)	60 x 30 (1.5 x .75m)
*1/2" (12.7mm)	365 (165kg)	72 x 36 (1.8 x .9m)	330 (150kg)	60 x 36 (1.5 x .9m)	285 (130kg)	48 x 36 (1.2 x .9m)
*3/8" (9.5mm)	235 (108kg)	48 x 44 (1.2 x 1.1m)	195 (90kg)	48 x 36 (1.2 x .9m)	155 (72kg)	48 x 30 (1.2 x .9m)

NEVER LIFT ANY LOADS WITH ANY DIMENSION GREATER THAN 96 INCHES (2.4 METERS) OR WITH A THICKNESS LESS THAN 3/8" (9.5 mm)

† Air Gap = nonmagnetic separation between magnet's lifting surface and load.

* Lifting capacity affected by peel and thickness. See notes 2 & 4 in the "Important Facts" and "Recommended Lifting Procedures" (See pages 6, 7 and 10).

NEO-1000

LIFTING GUIDELINES (ROUND BARS & PIPES)

Values shown are for maximum rated capacities when operating instructions and warnings are followed.

VALUES ARE BASED UPON AISI 1020 STEEL

Higher alloy steels and other magnetic materials will require further reductions of these rated capacities (See page 11 for the Guidelines for the reduction of the Rated Lifting Capacities.)

NEVER EXCEED EITHER THE MAXIMUM LENGTH or WEIGHT SHOWN FOR EACH ROUND BAR/PIPE DIAMETER, WALL THICKNESS & TYPE OF SURFACE CONDITION

Round Bar/Pipe Diameter Inches	Pipe Wall Thickness Inches	TYPE OF SURFACE CONDITION					
		CLEAN & SMOOTH Similar to a Flat (32 micro-inch RMS) Ground Surface .000" Max. Air Gap †		CLEAN & SMOOTH Similar to a Flat Hot Rolled Steel Surface .010" Max. Air Gap † (.254mm)		IRREGULAR OR ROUGH Similar to a Flat Smooth Cut File .020" Max. Air Gap † (.508mm)	
		Maximum Length Inches	Maximum Load Pounds	Maximum Length Inches	Maximum Load Pounds	Maximum Length Inches	Maximum Load Pounds
11" (254mm) MAX. DIA.	3/8"	31"	117	27"	97	21"	77
	1/2"	39"	182	35"	163	30"	141
	1"	66	587	58"	522	50"	449
	SOLID BAR	40"	1100	34"	925	26"	720
8" (203mm)	3/8"	46"	117	38"	97	30"	77
	1/2"	54"	182	49"	163	42"	140
	SOLID BAR	77"	1100	65"	925	50"	720
6" (152mm)	3/8"	62"	117	51"	97	41"	77
	1/2"	74"	182	67"	163	58"	140
	SOLID BAR	137"	1100	115"	925	90"	720
4" (101mm)	3/8"	96"	117	80"	97	63"	77
	1/2"	116"	182	105"	163	90"	140
	SOLID BAR	177"	629	177"	629	177"	629
3" (76mm) MIN. DIA.	3/8"	133"	117	110"	97	87"	77
	1/2"	114"	127	102"	114	89"	99
	SOLID BAR	177"	354	177"	354	177"	354

NEVER LIFT ROUND BARS OR PIPES WITH:
A diameter LESS THAN 3 Inches or
A diameter GREATER THAN 11 Inches or
A wall thickness LESS THAN 3/8" (9.5 mm) or
A length greater than shown in the Lifting Guidelines above
(Absolute maximum length 177" (4500mm))

† Air Gap = nonmagnetic separation between magnet's lifting surface and load.

NEO-2000 LIFTING GUIDELINES (PLATE)

Values shown are for maximum rated capacities when operating instructions and warnings are followed.

VALUES ARE BASED UPON AISI 1020 STEEL

Higher alloy steels and other magnetic materials will require further reductions of these rated capacities
(See page 11 for the Guidelines for the reduction of the Rated Lifting Capacities.)

NEVER EXCEED EITHER THE MAXIMUM WEIGHT OR SIZE SHOWN FOR EACH LOAD THICKNESS AND TYPE OF SURFACE CONDITION

LOAD THICKNESS Inches	TYPE OF SURFACE CONDITION					
	CLEAN & SMOOTH Similar to a Flat (32 micro-inch RMS) Ground Surface .000" Max. Air Gap †		RUST OR SCALE Similar to a Flat Hot Rolled Steel Surface .010" Max. Air Gap † (.254mm)		IRREGULAR OR ROUGH Similar to a Flat Smooth Cut File .020" Max. Air Gap † (.508mm)	
	Max. Load (lbs.)	Max. Size (in.)	Max. Load (lbs.)	Max Size (in.)	Max Load (lbs.)	Max Size (in.)
4" & above (76mm & above)	4400 (2000kg)	-	2860 (1300kg)	-	2420 (1100kg)	-
*2" (51mm)	2750 (1250kg)	96 x 48 (2.4 x 1.2m)	2150 (980kg)	78 x 48 (1.95 x 1.2m)	1890 (860kg)	68 x 48 (1.7 x 1.2m)
*1" (25.4mm)	1430 (650kg)	96 x 48 (2.4 x 1.2m)	1210 (550kg)	88 x 48 (2.2 x 1.2m)	1045 (475kg)	72 x 48 (1.8 x 1.2m)
*3/4" (20mm)	880 (400kg)	96 x 48 (2.4 x 1.2m)	825 (375kg)	88 x 42 (2.21 x 1.1m)	770 (350kg)	72 x 48 (1.8 x 1.2m)

NEVER LIFT ANY LOADS WITH ANY DIMENSION GREATER THAN 96 INCHES (2.4 METERS) OR WITH A THICKNESS LESS THAN 3/4" (20 mm)

† Air Gap = nonmagnetic separation between magnet's lifting surface and load.

* Lifting capacity affected by peel and thickness. See notes 2 & 4 in the "Important Facts" and "Recommended Lifting Procedures" (See pages 6, 7 and 10).

NEO-2000

LIFTING GUIDELINES (ROUND BARS & PIPES)

Values shown are for maximum rated capacities when operating instructions and warnings are followed.

VALUES ARE BASED UPON AISI 1020 STEEL

Higher alloy steels and other magnetic materials will require further reductions of these rated capacities (See page 11 for the Guidelines for the reduction of the Rated Lifting Capacities.)

NEVER EXCEED EITHER THE MAXIMUM LENGTH or WEIGHT SHOWN FOR EACH ROUND BAR/PIPE DIAMETER, WALL THICKNESS & TYPE OF SURFACE CONDITION

Round Bar/Pipe Diameter Inches	Pipe Wall Thickness Inches	TYPE OF SURFACE CONDITION					
		CLEAN & SMOOTH Similar to a Flat (32 micro-inch RMS) Ground Surface .000" Max. Air Gap †		CLEAN & SMOOTH Similar to a Flat Hot Rolled Steel Surface .010" Max. Air Gap † (.254mm)		IRREGULAR OR ROUGH Similar to a Flat Smooth Cut File .020" Max. Air Gap † (.508mm)	
		Maximum Length Inches	Maximum Load Pounds	Maximum Length Inches	Maximum Load Pounds	Maximum Length Inches	Maximum Load Pounds
13.75" (350mm) MAX. DIA.	3/4"	51"	440	48"	412	44"	385
	1"	63"	715	53"	605	46"	522
	SOLID BAR	52"	2200	47"	1980	42"	1760
11" (279mm)	3/4"	64"	440	60"	412	56"	385
	1"	80"	715	68"	605	59"	522
	SOLID BAR	82"	2200	74"	1980	65"	1760
8.625" (203mm)	3/4"	84"	440	78"	412	73"	385
	1"	105"	715	89"	605	77"	522
	SOLID BAR	133"	2200	120"	1980	106"	1760
8" (152mm)	3/4"	91"	440	85"	412	80"	385
	1"	115"	715	97"	605	84"	522
	SOLID BAR	155"	2200	139"	1980	124"	1760
6" (152mm) MIN DIA.	3/4"	126"	440	118"	412	110"	385
	1"	160"	715	136"	605	117"	522
	SOLID BAR	196"	1570	177"	1415	157"	1255

NEVER LIFT ROUND BARS OR PIPES WITH:
A diameter LESS THAN 6 Inches or
A diameter GREATER THAN 13.75 Inches or
A wall thickness LESS THAN 3/4" (20 mm) or
A length greater than shown in the Lifting Guidelines above
(Absolute maximum length 196" (5000mm))

† Air Gap = nonmagnetic separation between magnet's lifting surface and load.

INSPECTION AND MAINTENANCE INSTRUCTIONS

EVERY LIFT

- Keep the lifting surfaces of the magnet CLEAN, SMOOTH, FLAT, FREE OF RUST and any FOREIGN MATERIALS. Nicks and burrs on the lifting surfaces will reduce the lifting capacity. If burrs occur, they can be removed by filing or hand stoning them away. However, care must be taken to protect the neighboring lifting surfaces.
- Check the operation of the handle. The handle shaft should move freely when extended and return promptly upon release. If the handle shaft binds and remains extended, **DO NOT CONTINUE TO USE THE MAGNET**. This handle shaft is a safety feature to prevent an inadvertent release of the load.

DAILY

- Check the entire magnet's case, lifting surfaces, eye-hook, and welds for cracks or other defects. If present, **DO NOT USE THE MAGNET** – Contact a Qualified Person* or O. S. Walker.
- Inspect the eyehook for wear or deformation. If the eyehook is deformed and/or the diameter of the eyehook is worn to less than 5/16" (0.313), 7/16" (0.438") for the NEO-250 & NEO-500 or 9/16" (0.563") for the NEO-1000 and NEO-2000 it should be replaced.
- Check the condition of the Product Safety/Operating Instruction label and the Lifting Guidelines/Specification label. If they are missing or damaged, they must be replaced. Your magnet was supplied with one (1) Lifting Guidelines label, (1) Operating Instruction label, and one (1) Product Safety Poster.
- Inspect all socket head cap screws. Retighten and/or replace if necessary.

WEEKLY

- All the lifting surfaces of the magnet should be checked for flatness and wear. Uneven wear and out of flatness can greatly reduce the lifting capacity because it will cause a non-magnetic separation (air gap) between the magnet and the surface of the load. Some nicks and burrs will occur on the magnet's lifting surfaces due to normal usage. They should be filed or ground away with an abrasive stone. However, when the flat contact area of the entire magnet's lifting surfaces becomes less than 90% of the original total lifting surfaces, **it should be taken out of service and repaired or replaced.**
- The NEO-125, NEO-250, NEO-500, NEO-1000 & the NEO-2000 lifting magnets have specially shaped poles to ensure that the full magnetic intensity is directed into the load. Machining of the flat portion of the magnet's poles that contact flat plates & bars, will increase the width of the pole contact. This will reduce the magnetic intensity directed into the load. Also, changing the angle of taper of the pole and or the thickness will change the lifting characteristics of the magnet. Attaching or welding other materials to the lifting surfaces in order to reduce wear should not be done with this magnet because it will greatly reduce the lifting capacity. Contact O.S. Walker or a Qualified Person* for proper repair instructions. If machining is done to the poles, the magnet must be re-tested for break-away force in accordance with the test described in ASME B30.20.**
- Check the entire magnet's case, lifting surfaces, eye hook, and welds for cracks or other defects. If present, **DO NOT CONTINUE TO USE THE MAGNET**. Contact a Qualified Person* or O.S. Walker Co.

O.S. Walker recommends that your lifting magnet be re-tested for breakaway force each year. This product is manufactured in accordance with ASME B30.20 safety standard. (For further information refer to Chapter 20-3 Close Proximity Operated Magnets.)**

* **Qualified Person** - A person who by extensive knowledge, training and experience, has successfully demonstrated the ability to solve or resolve problems related to Walker lifting magnets.

** The American Society of Mechanical Engineers, Three Park Avenue, New York, NY 10016-5990

SPECIFICATION & SPARE PARTS LIST

Model No	NEO-125	NEO-250	NEO-500	NEO-1000	NEO-2000
Length	3.63"	5.94"	9.69"	12.44"	18.89"
Width	2.31"	3.94"	4.72"	5.79"	6.50"
Height to Hook	4.31"	6.61"	6.61"	8.50"	9.88"
Net Weight	6.2 lbs.	22 lbs.	42 lbs.	80 lbs.	198 lbs.
Rated Lift Cap.	0 - 275 lbs.	0 - 550 lbs.	0 - 1100 lbs.	0 - 2200 lbs.	0 - 4400 lbs.

ITEM NO.	DESCRIPTION OF PARTS	MODEL				
		NEO-125	NEO-250	NEO-500	NEO-1000	NEO-2000
1	MAGNET, COMPLETE	64-H44.05.125	64-AXM12426	64-AXM12427	64-AXM12463	64-AXM13175
2	PRODUCT SAFETY/OPERATING INSTRUCTION LABEL	37-DD15557	37-DD15559	37-DD15561	37-DD15563	37-DD15564
3	LIFTING GUIDELINES LABEL	37-DD15558	37-DD15560	37-DD15562	37-DD15564	37-DD15566
4	HANDLE ASSEMBLY	39-DD16214	37-DD14547	39-DD14547	39-DD14548	39-DD15662
5	HANDLE MOUNTING BLOCK KIT	39-DD16215	39-DD14549	39-DD14549	39-DD14560	39-DD15663

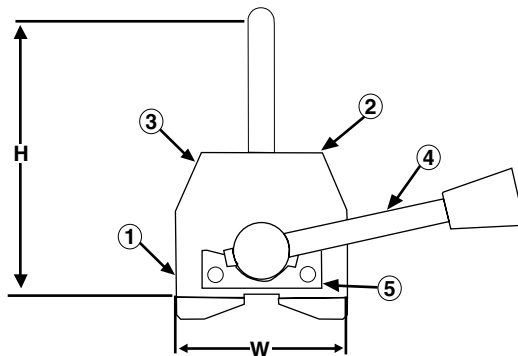

REPAIRS

For repair of your lift magnet, contact O.S. Walker for your nearest Authorized Service Center TOLL FREE at 1-800-W-MAGNET. A return material authorization number will be issued along with the address of the nearest Authorized Service Center. Your magnet, after receipt by the Service Center will be inspected and a free estimate of repair charges will be provided. Authorization for repairs from magnet owners must be given to the O.S. Walker Service Center before repairs are made. Transportation charges, both to and from the factory, are to be paid by the magnet owner.

WARNING

- Disassembly or repair of this magnet can result in reduced holding power and/or cause an unsafe condition. Therefore, anytime the magnet is disassembled beyond the parts list shown in this manual, the magnet must be re-tested for breakaway force in accordance with the test described in ANSI/ASME B30.20.
- Modification of any operating mechanism or structure of this magnet can reduce the magnet's effectiveness and/or cause unsafe conditions.
- Repair or modification of this magnet should only be done by O.S. Walker or a Qualified Person.*

* **Qualified Person** - A person who by extensive knowledge, training and experience, has successfully demonstrated the ability to solve or resolve problems related to Walker lifting magnets. (Walker replacement parts may be installed by a ****Designated Person.**)

** **Designated Person** - A person selected or assigned by the employer as being competent to replace specific replacement parts listed in this manual and is able to verify the proper functioning of the specific replacement parts and the entire product after the completion of the installation.

OPERATOR'S MANUAL AND SAFETY INSTRUCTIONS

WITH INSPECTION AND MAINTENANCE INSTRUCTIONS
NEO-HV 250, NEO-HV 500, NEO-HV 1000

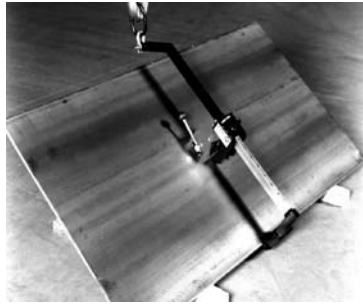
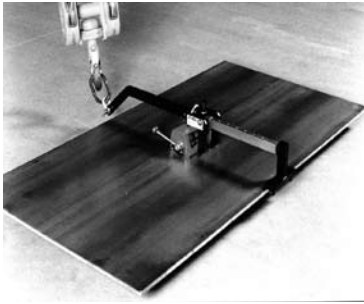

To expand your handling possibilities you can purchase Lifting arms, HV 250, HV 500 and HV 1000 separately and retrofit them to your NEO 250, 500, and 1000 lifting magnet. With the HV lifting arm installed, the lifting magnet can be used for turning workpieces from the horizontal into the vertical position and vice-versa. A very convenient means for loading and unloading of horizontal machining centers and other machines. With this arrangement, the magnet can be adjusted to accommodate a range of flat plates & flat circular disks.

A NEO-HV lifting device is comprised of one HV lifting arm (HV 250, HV 500 or HV 1000) attached to the correct NEO lifting magnet (NEO 250, 500, or 1000).

Check upon delivery that the lifting arm is complete and undamaged. Apart from this manual the delivery of a HV lifting arm consists of:

- ◆ The lifting arm HV 250, HV 500, or HV 1000 assembly and one allen key.



Never use a damaged or improperly functioning device!

INSTALLATION OF THE HV LIFTING ARM

- 1 Take the end plate (4 socket head screws) off the slider.
- 2 Remove the lifting eye from the arm.
- 3 Insert the end of the lifting arm into the lifting eye of the magnet. The magnet's operating lever should be on the same side as the text plate of the lifting arm. (As shown in Figure 1 below.)



Figure 1



Figure 2



Figure 3

- 4 Push the lifting arm forward until the lifting eye of the magnet falls into the slider. (See Figure 2.)
- 5 Mount the end plate.
- 6 Tighten the (4) screws properly. (See figure 3)
- 7 Replace and secure the lifting eye to the arm.

CAUTION:

- ◆ Confirm that the correct magnet model is mounted on the correct HV arm. Always use a NEO 250 magnet with a HV 250 arm, a NEO 500 magnet with a HV 500 arm, and a NEO 1000 magnet with a HV 1000 arm.
- ◆ Confirm that the magnet has freedom to tilt and twist slightly.
- ◆ Confirm that the arm's slider moves with ease.
- ◆ Confirm that the locking pin in the arm's slider locks into the arm properly.

SAFETY PRECAUTIONS

Never attempt to operate this NEO-HV 250, 500, or 1000 lifting device until you read and understand the NEO series magnet Operator's Manual and Safety Instructions (DD-14493), and these NEO-HV operating and safety instructions.



Figure 4

- 1 **ALWAYS STAY CLEAR OF THE LOAD.** **Never** get in a position where you could get hit with the load if it should come off the magnet.
- 2 **Always** position the magnet so that it is slightly **below** the center of gravity of the workpiece when in **vertical** position. (See Figure 4 & Figure 5)
- 3 In the **vertical** position, the lifting device together with the workpiece should always lean **a few degrees forward**. (With the device on "top side" see Figure 4.)
- 4 **Never** exceed the workload limits corresponding to the material thickness, surface quality, and type of material. Refer to the guidelines for the Reduction of Rated Lifting Capacity on page 11.

WORKLOAD LIMITS

Read and understand the Lifting magnet's instruction (Manual # 37-DD-14493) before lifting any load!

The workload limit depends on:

- ◆ Surface quality, flatness, rust, scale, paint, dirt etc.
- ◆ Material thickness
- ◆ Length/width relation (sagging/peeling)
- ◆ Type of material
- ◆ Contact area

	NEO-HV 250	NEO-HV 500	NEO-HV 1000
Rated Lift Capacity (On Flat AISI 1020 steel)	0 - 550 lbs.	0 - 1100 lbs.	0 - 2200 lbs.
Plate Width (W) (Min./Max.)	11.8 - 31.5 in.	11.8 - 39.4 in.	11.8 - 39.4 in.
Plate Length (L) (Min./Max.)	8 - 60 in.	12 - 72 in.	12.5 - 79 in.
Plate Thickness (Min./Max.)	0.25 - 5.9 in.	0.31 - 9.8 in.	0.39 - 11.8 in.

Flat workpieces only!

Do not lift plate's thinner than indicated in the table!

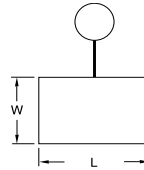

OPERATING INSTRUCTIONS

Before every lift: Check surfaces of magnet and load. These must be clean, smooth, flat, free of rust and any foreign particles!

IMPORTANT!

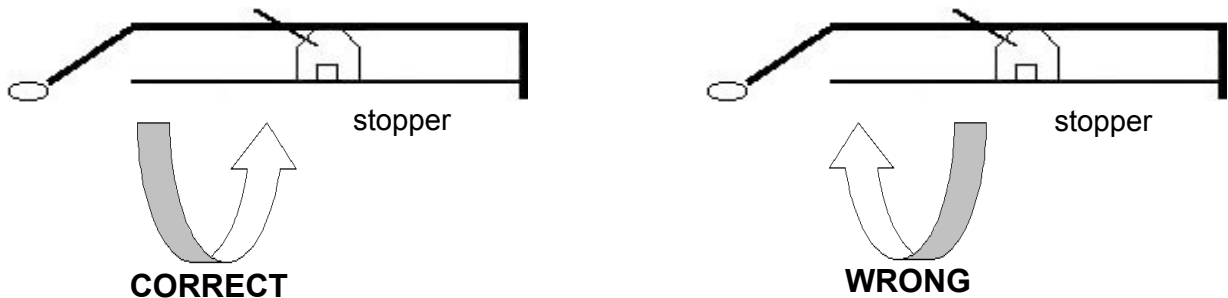

Figure 5

During handling the **stopper must sit tight against the edge** of the workpiece at all times. The **sliding force must** be counteracted **by the stopper**. Therefore the lifting magnet should always be placed **off the center** of gravity of the workpiece in order for the workpiece to create a torque forcing itself against the stopper.

From Horizontal to Vertical Position:

1. Place the magnet on the load and push the stopper firmly against the future lower edge of the load.
2. Adjust the position of the magnet according to the size of the load so that it is slightly off center and **below** the center of gravity. (See Figure 5) when the plate is in **vertical** position. Make sure the locking pin on the slider is engaged in the hole on the arm.
3. Make sure the stopper remains pressed against the edge of the load! Push the stopper against the edge of the load again if required.
4. Switch the magnet ON; the **lever** must **lock** in place.
5. **Stand clear** of the device and lift the workpiece a few inches.
6. Jar the workpiece firmly to **make sure adequate holding force** is available.
7. Now slowly lift up to the vertical position, but beware that the arm does not “overshoot” the **90° angle**. If necessary correct the vertical angle by means of the position of the lifting eye.
8. Move the load **carefully** and **smoothly**. Avoid shocks and collisions and **ALWAYS STAY CLEAR OF THE LOAD**.
9. The load must remain vertical during transport to avoid the load from sliding away from the stopper.
10. Set down and **secure**. Only now switch OFF the magnet, the **lever** must **lock in place**.

From Vertical to Horizontal Position:

- 1 Push the device against the workpiece surface on the centerline and adjust the position of the magnet according to the size of the load so that it is slightly off center and **below** the center of gravity. (See Figure 5) **Make sure the locking pin on the slider is engaged in the slot.**
- 2 Push the stopper **firmly** against the lower edge of the workpiece.
- 3 Switch the magnet ON; the **lever** must **lock** in place.
- 4 Detach, stand clear, and lift the workpiece. Check the vertical angle. If required adjust the position of the lifting eye so that the load **leans forward** slightly.
- 5 Jar the load to **make sure adequate holding** is available.
- 6 Move the workpiece **carefully** and **smoothly**. Avoid shocks and collisions and **ALWAYS STAY CLEAR OF THE LOAD.**
- 7 The load must remain vertical during transport to avoid the load from sliding away from the stopper.
- 8 Lower the workpiece slowly to horizontal position and **make sure that the lifting arm does not slide away** uncontrollably. **Secure** the load.
- 9 Only now switch OFF the magnet, the **lever** must **lock in place.**

HV INSPECTION AND MAINTENANCE

Also see Inspection and Maintenance Instructions for the magnet on page 20.

DAILY

- Check condition and function of slider and locking pin.

WEEKLY

- Check lifting arm for deformations, cracks, and wear. Replace the lifting eye if worn for more than 10%. Grease slider and locking pin.
- Replace a damaged and/or illegible text plate.

ANNUALLY

- Have the device inspected and tested by O. S. Walker or by a qualified person.

HV SPARE PARTS LIST

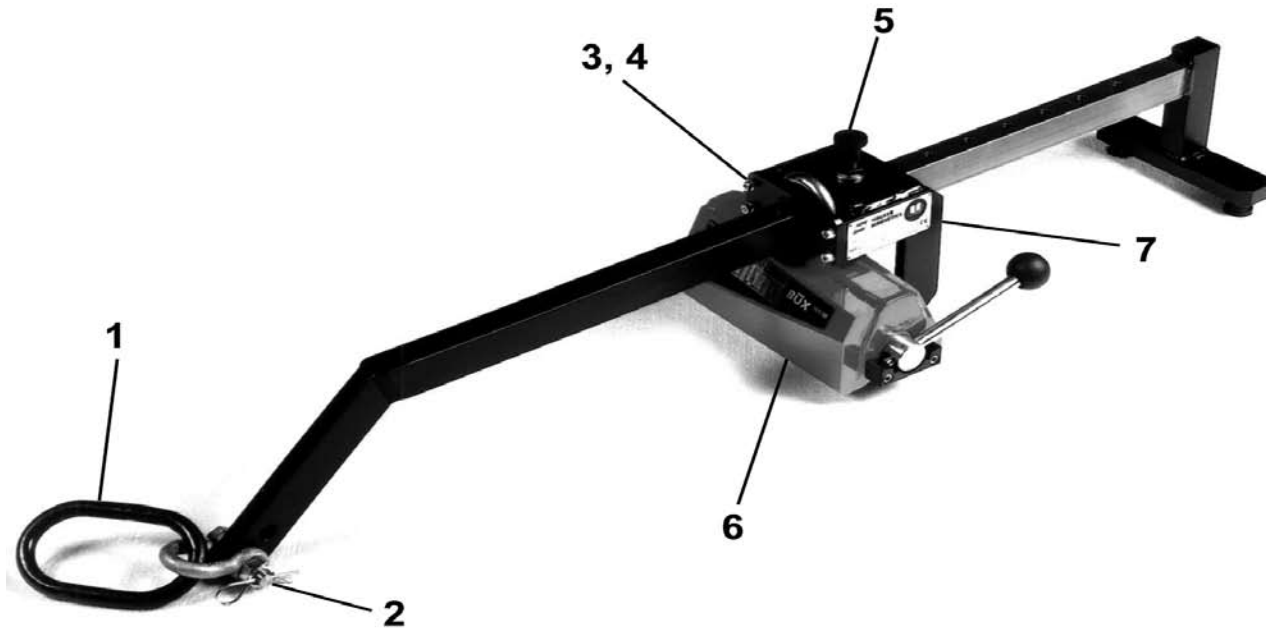

ITEM	DESCRIPTION	NEO-HV-250		NEO-HV-500		NEO-HV-1000	
		PART NO.	QTY.	PART NO.	QTY.	PART NO.	QTY.
1	OBLONG LINK	393.26.88	1	393.26.88	1	393.25.95	1
2	SHACKLE	393.20.34	1	393.20.34	1	393.25.92	1
3	PLATE	A4-744.05.89	1	A4-744.05.75	1	A4-744.06.02	1
4	SCREW	363.01.56	4	363.01.56	4	363.01.56	4
5	PLUNGER	393.22.45	1	393.22.45	1	393.22.45	1
6	MAGNET	440.52.50	1	440.55.00	1	440.50.00	1
7	LABEL	369.10.21	1	369.10.21	1	369.10.21	1

ALWAYS STAY CLEAR OF THE LOAD

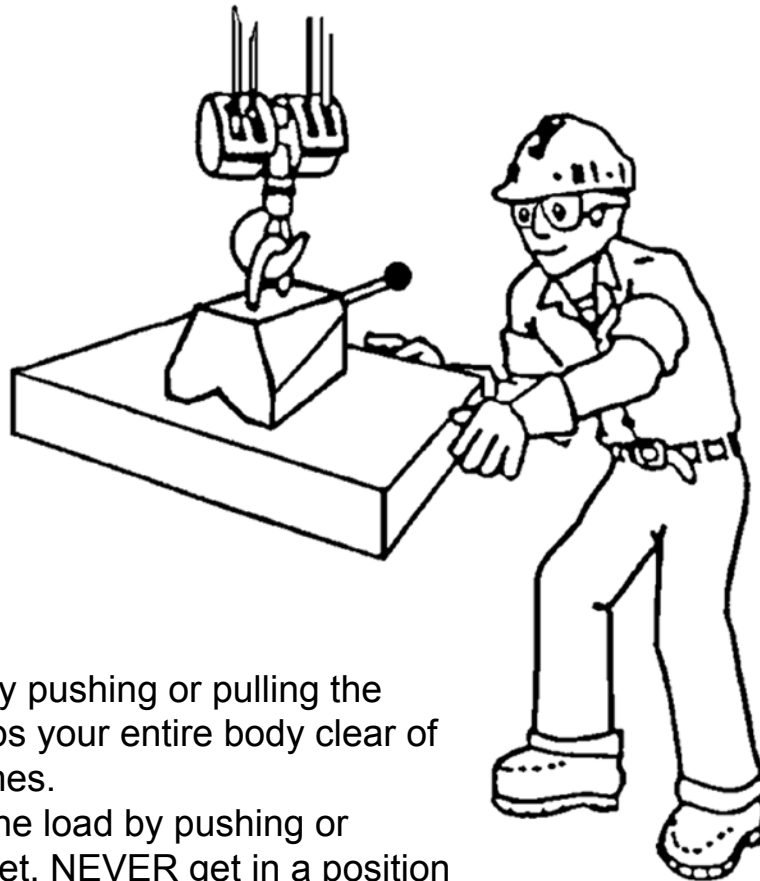

Guide the load by pushing or pulling the edges. This keeps your entire body clear of the load at all times.

DO NOT guide the load by pushing or pulling the magnet. NEVER get in a position where you could get hit with the load if it is dropped.

FOR FAST RESPONSE, CALL 1-800-W-MAGNET

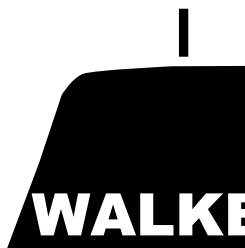

O.S. WALKER

Rockdale Street, Worcester, MA 01606

(508) 853-3232 FAX (508) 852-8649

1-800-W-MAGNET

3508 Glenridge Drive, Chino Hills, CA 91709

(909) 597-4785 FAX (909) 597-0581

901 Arvin Avenue, Stoney Creek, Ontario, L8E5N9 Canada

(905) 643-3338

In Canada: 1-800-267-4678 FAX (905) 643-6111

www.walkermagnet.com

e-mail: info@walkermagnet.com